



Installation, Operation & Maintenance Instruction Manual



PULSAR[®] DLC NEMA TYPE 4X DIGITAL STROKE LENGTH CONTROLLER

Bulletin No.: IOM-CTL-DLC-2005 Rev A

Copyright © 2001-2015 Pulsafeeder, Inc. All rights reserved.
PULSAR is a registered trademark of Pulsafeeder, Inc.

Factory Service Policy

PULSAR® DLC Controllers are microprocessor- based stroke length and controllers intended for use with PULSAR Diaphragm Metering Pumps. They include extensive on-board diagnostics. If you are experiencing a problem with your PULSAR DLC Controller, first review the diagnostic menu, then consult the troubleshooting guide. If the problem is not covered or cannot be solved, please contact your local PULSA Series Sales Organization or our Technical Service Department at (585) 292-8000 for further assistance. **Do not open or tamper with the DLC enclosure as this will void the warranty set forth below.**

Trained individuals are available to help you diagnose your problem and arrange a solution. Solutions may include purchasing a replacement unit or returning the DLC to the factory for inspection and repair.

All returns require a Return Material Authorization (RMA) number to be issued by Pulsafeeder. Replacements purchased under a possible warranty situation may be credited if, after an examination of the original PULSAR DLC Controller by Pulsafeeder, it is determined that the issue is covered by the warranty set forth below.

Certain components may be purchased for replacement. Refer to **Section 15: Spare Parts** for more information and part numbers. Parts purchased to correct a warranty issue may be credited if after examination of the original parts by Pulsafeeder personnel it is determined that the issue is covered by the warranty set forth below. Parts returned for warranty consideration that test satisfactorily or are otherwise not covered by the warranty set forth below will be returned freight collect unless Pulsafeeder is directed otherwise.

Field modifications will void the warranty set forth below. Out-of-warranty repairs will be subject to Pulsafeeder's standard bench fees and testing costs associated with replacement components.

Warranty

Pulsafeeder warrants its PULSAR DLC Controllers to be free of defects in material and workmanship under normal use and service for a period of one year from the date of shipment from Pulsafeeder's factory in Rochester, New York, USA. This warranty applies only to products which are properly stored, installed, operated and maintained. In order to be considered properly stored, installed, operated and maintained, a product (i) must be shaded from direct sunlight, (ii) must not be used in conditions that expose them to ambient temperatures below 32°F/0°C or above 120°F/49°C, (iii) must be protected against environmental conditions, and (iv) must be stored, installed, operated and maintained in accordance with all instructions and directions in Pulsafeeder's installation, operation and maintenance manuals for the product.

Before returning a product or part for warranty consideration, the claimant must first contact Pulsafeeder, describe the claim, identify the product model and serial numbers for which claim is being made, and submit proof of purchase and date of startup. If Pulsafeeder is willing to accept the warranty claim without return of the product or part, it shall so advise the claimant. If Pulsafeeder believes the warranty claim may potentially be a valid but is not willing to accept the warranty claim without return of the product or part, it will provide a written return authorization to the claimant. Following receipt of the written return authorization, the claimant may deliver the product or part to Pulsafeeder at its factory in Rochester, New York, USA, freight and duties prepaid. The written return authorization must be included with the returned product or part. Pulsafeeder has no liability or obligation with respect to products or parts that are returned without a written return authorization.

Upon receipt of the returned product or part, a thorough examination will be conducted by Pulsafeeder to determine the cause of the issue with the product or part and whether it is covered

by this warranty. This determination shall be made by Pulsafeeder in its sole reasonable judgement. If Pulsafeeder determines the issue with the returned product or part is not covered by this warranty, a report of Pulsafeeder's findings will be sent to the claimant.

Pulsafeeder's sole liability and obligation and the claimant's exclusive right and remedy under this warranty shall be limited to the replacement or repair of the defective product or part. The decision whether to replace or repair shall be made by Pulsafeeder in its sole discretion. Without in any way limiting the foregoing, Pulsafeeder shall not be liable under this warranty (i) for any costs of removal, installation, transportation or any other changes which may arise in connection with a warranty claim, (ii) for any loss, damage, injury, cost or expense directly or indirectly related to the use or failure of its products, including, but not limited to, any loss of or damage to other products, machinery, buildings or property and any injury to persons, or (iii) for consequential damages (including, but not limited to, loss of time, inconvenience, loss of product being pumped, loss of production, loss of business, or loss of contract),

This warranty shall be null and void with respect to a Pulsa Series or PULSAR Metering Pump if in the sole reasonable judgment of Pulsafeeder (i) it has been tampered with, disassembled, repaired or altered by anyone other than Pulsafeeder (unless authorized by Pulsafeeder in writing and then only if carried out strictly in accordance with Pulsafeeder's written instructions and directions), (ii) it has not been properly stored, installed, operated and maintained, or (iii) it has been used for a purpose or application for which it is not fit or appropriate. This warranty does not cover normal wear and tear of a product or damage to a product during shipment or after receipt.

PURCHASERS AND USERS OF PULSAR DLC CONTROLLERS ARE SOLELY RESPONSIBLE FOR DETERMINING THE FITNESS AND APPROPRIATENESS OF SUCH PRODUCTS FOR THE PURPOSES AND APPLICATIONS FOR WHICH THEY ARE USED, AND PULSAFEEDER SHALL HAVE NO LIABILITY OR OBLIGATION UNDER THIS WARRANTY OR OTHERWISE IF A PULSAR DLC CONTROLLER IS USED FOR A PURPOSE OR APPLICATION FOR WHICH IT IS NOT FIT OR APPROPRIATE.

THIS WARRANTY IS PULSAFEEDER'S SOLE WARRANTY AND IS IN LIEU OF ALL OTHER WARRANTIES, EXPRESS OR IMPLIED, INCLUDING, BUT NOT LIMITED TO, ALL IMPLIED WARRANTIES OR MERCHANTABILITY AND FITNESS FOR A PARTICULAR PURPOSE, WHICH WARRANTIES ARE HEREBY EXPRESSLY EXCLUDED.

NO DISTRIBUTOR OR OTHER PERSON IS AUTHORIZED TO MAKE ANY WARRANTY OR GUARANTEE OR AGREE TO OR ACCEPT ANY LIABILITY OR OBLIGATION ON BEHALF OF PULSAFEEDER OTHER THAN AS EXPRESSLY PROVIDED HEREIN.

Liability Exclusion and Limitation

To the maximum extent permitted by law:

- Pulsafeeder shall have no responsibility or liability for any personal injury, property damage or other loss or damage of any kind with respect to any PULSAR DLC Controller that:
 - is not properly stored, installed, operated and maintained. In order to be considered properly stored, installed, operated and maintained, a PULSAR DLC Controller (i) must be shaded from direct sunlight, (ii) must not be used in conditions that expose them to ambient temperatures below 32°F/0°C or above 120°F/49°C, (iii) must be protected against environmental conditions, and (iv) must be stored, installed, operated and maintained in accordance with all instructions and directions in Pulsafeeder's installation, operation and maintenance manuals for the product .
 - is tampered with, disassembled, repaired or altered (except as may be authorized by Pulsafeeder in writing and then only if carried out strictly in accordance with Pulsafeeder's written instructions and directions)
 - is used for a purpose or application for which it is not fit or appropriate
 - is damaged during shipment or after receipt
- Pulsafeeder shall have no responsibility or liability for any:
 - costs of removal, installation, transportation or any other changes which may arise in connection with a warranty claim or other issue with a PULSAR DLC Controller
 - loss, damage, injury, cost or expense directly or indirectly related to the use or failure of its products, including, but not limited to, any loss of or damage to other products, machinery, buildings or property and any injury to persons
 - consequential damages (including, but not limited to, loss of time, inconvenience, loss of product being pumped, loss of production, loss of business, or loss of contract)

Information in this manual is subject to change without notice. No part of this manual may be reproduced, stored in a retrieval system, or transmitted in any form or any means, electronic or mechanical, including photocopying and recording, for any purpose other than installing, operating and maintaining the PULSAR DLC Controller for which it is provided without the written permission of Pulsafeeder.

FCC Warning

This equipment generates and uses radio frequency energy. If not installed and used properly, in strict accordance with the manufacturer's instructions, it may cause interference to radio communications. Operation of this equipment in a residential area is likely to cause interference in which cases the user, at his own expense, will be required to take whatever measures necessary to correct the interference.

Copyright © 2001 - 2015 Pulsafeeder, Inc. All rights reserved.

Information in this document is subject to change without notice. No part of this publication may be reproduced, stored in a retrieval system or transmitted in any form or any means electronic or mechanical, including photocopying and recording for any purpose other than the purchaser's personal use without the written permission of Pulsafeeder.

Conventions

For the remainder of this bulletin, the following conventions are in effect.



A WARNING DEFINES A CONDITION THAT COULD CAUSE DAMAGE TO BOTH THE EQUIPMENT AND THE PERSONNEL OPERATING IT. THIS MANUAL MUST BE CONSULTED IN ALL CASES WHERE THE WARNING SYMBOL IS MARKED IN ORDER TO FIND OUT THE NATURE OF THE POTENTIAL HAZARDS AND ANY ACTIONS WHICH HAVE TO BE TAKEN TO AVOID THEM.



CAUTION, POSSIBILITY OF ELECTRIC SHOCK.



NOTES ARE GENERAL INFORMATION MEANT TO MAKE OPERATING THE EQUIPMENT EASIER.



TIPS HAVE BEEN INCLUDED WITHIN THIS BULLETIN TO HELP THE OPERATOR RUN THE EQUIPMENT IN THE MOST EFFICIENT MANNER POSSIBLE. THESE “TIPS” ARE DRAWN FROM THE KNOWLEDGE AND EXPERIENCE OF OUR STAFF ENGINEERS, AND INPUT FROM THE FIELD.



THIS IS A PROCEDURE HEADING. A PROCEDURE HEADING INDICATES THE STARTING POINT FOR A PROCEDURE WITHIN A SPECIFIC SECTION OF THIS MANUAL.

Revision History

REV LEVEL	BRIEF DESCRIPTION	DATE
-	New bulletin number	08/28/2015
A	2.2 Explosive Atmosphere	11/20/2015

REVISION LOG

-	New, updated to current certified design
A	Updated atmosphere safety and warnings for explosion hazards

Table of Contents

1	Introduction.....	1
1.1	Description.....	1
1.2	DLC Standard Features	2
1.3	Options.....	2
2	Safety Considerations	2
2.1	General Safety	2
2.2	Explosive Atmosphere Safety.....	3
2.3	Electrical Safety.....	3
2.4	Fire Safety	3
2.5	Mechanical Safety	4
2.6	Hydraulic Safety	4
2.7	Liability Exclusion.....	4
2.8	Pump Suitability to Site of Installation	4
3	Transport and Inspection	5
3.1	Consignment receipt and un-packaging	5
3.2	Handling.....	5
3.3	Lifting	5
3.4	Recycling and end of product life	5
4	Storage Instructions.....	5
4.1	Storage Length.....	5
4.1.1	Short Term (0 - 12 months).....	5
4.1.2	Long Term (12 months or more)	6
5	Installation.....	6
5.1	Location	6
5.2	Installation Notes	7
5.3	Electrical Wiring	7
5.3.1	Getting Started	8
5.3.2	Finding your way around the Field Wiring Board	9
5.4	High-Voltage Connections	10
5.4.1	Supply Power	10
5.4.2	PULSAR Pump Motor	11
5.4.3	Alarm Relay	12
5.5	Low-Voltage Input Connections	12
5.5.1	Analog Inputs	13
5.5.2	Alarm Input.....	13
5.5.3	Level Input (Remote Start/Stop).....	13
5.6	Low-Voltage Output Connections	14
5.6.1	Current Output	14
5.6.2	Alarm Dry Contact Output	14
5.6.3	Run Status or Stroke Counter	15
5.7	Serial Communications Input	15
5.7.1	Important Wiring Detail	16
5.8	Fuse Replacement.....	17
6	Startup Instructions	18
6.1	Overview	18
6.1.1	User Interface Familiarization.....	18
6.1.2	Check Wiring and Close Access Cover.....	20
6.1.3	Confirm Correct Incoming Power	20
6.1.4	Confirm Display and Keypad Functionality	21
6.1.5	Performing a Factory Re-initialization	21
6.1.6	Test Pump Motor.....	22
6.1.7	Set Time and Date.....	23
6.1.8	Flow Calibration (1-point)	23
6.1.9	Analog Input Calibration	24
7	General Operation	25
7.1	General Operation Instructions	25
7.1.1	Pump Flow Calibration.....	25
7.1.2	Analog Input Signal Calibration	29

7.1.3	Reverse Acting Analog Input Signal Calibration	31
7.1.4	Analog Output Signal Calibration	32
7.2	Menu	33
7.2.1	Alarm and Error Messages	34
7.2.2	Diagnostics	35
7.2.3	Set Time and Date	37
7.2.4	Analog Signal Failure Setup	39
7.2.5	MODBUS Signal Failure Setup	41
7.2.6	Leak-Detection Failure Setup	43
7.2.7	Level / Remote Start-Stop Setup	45
7.2.8	Digital Output Setup	47
7.2.9	Motor Thermostat Setup	49
7.2.10	Over Temperature Setup	50
7.2.11	Power Failure Setup	51
7.2.12	Alarm Relay	52
7.2.13	Analog Mode	53
7.2.14	MODBUS Mode	54
7.2.15	Security	56
7.2.16	Number Format	57
7.2.17	Contrast Adjust	58
7.2.18	Serial Communications	58
7.2.19	Serial Diagnostics	61
7.2.20	Language	64
7.2.21	Factory Defaults Reset Procedure	64
7.3	Units	65
7.4	Varying the Flow Rate - Manually	65
7.5	Mode	66
7.6	Batch	66
7.6.1	One-Time Only	66
7.6.2	Repeating	67
7.6.3	Overlapped	67
8	Diagrams: Installation / Component	71
9	Specifications	73
10	Factory Default Values	76
11	Troubleshooting Guide	79
11.1	System Diagnostics	79
11.2	Encoder Diagnostics	86
11.2.1	Troubleshooting	87
11.2.2	Encoder/Gear Train Access	89
11.2.3	Encoder Replacement	89
12	Conversion (Manual to DLC)	91
13	General Repairs	93
13.1	Emergency Manual Pulsar Operation	93
13.2	DLC Removal and Replacement	93
14	PULSAnet Specification	99
14.1	Introduction	99
14.2	Operational Overview	99
14.3	MODBUS Messaging	100
14.4	PULSAnet DDE Server Messaging	100
14.5	Coils	101
14.6	Input Bits (1X References)	101
14.7	Input Registers	102
14.8	Holding Registers	102
14.9	MODBUS Mode	107
14.9.1	Introduction	107
14.9.2	General Discussion	107
15	Spare Parts	107

1 Introduction

The DLC is an advanced microprocessor based controller designed for use with the PULSAR diaphragm metering pump. It controls the output of the pump by varying its stroke rate and the amount of fluid discharged with each stroke. It has many advanced features that allow it to operate in a wide variety of industrial environments. The operation and maintenance of the *PULSAR* metering pump is covered in the pump IOM. Please refer to this IOM for important safety and operational instructions for your PULSAR pump.

This instruction manual covers all standard features of the DLC and where applicable, specific options.

1.1 Description

The DLC is a pump mounted stroke length and drive motor (on/off) controller. Its purpose is to precisely adjust the flow of a process media by adjusting the pump stroke length.

The DLC is designed for the international industrial market. The device is factory configured and calibrated for the attached pump. The man/machine interface is user friendly. Local setup and control is achieved through the nine button keypad and a back-lit two-line liquid crystal display. Pump output is displayed as a percentage of stroke length position or in units of calibrated flow: CMH, GPH, LPH, CCH, CMM, GPM, LPM, or CCM. In addition, the DLC display supports any one of four languages: English, French, German or Spanish.

The DLC supports a variety of remote control options. These inputs and outputs are fully isolated for improved protection and reliability. A Batch feature, with up to three independent programs, supplements the control features and allows for greater flow turn down.

The DLC includes the *PULSAnet* Serial Communications system. This allows the DLC to interface digitally to other DLC's, PLC's, or PC's using the MODBUS™ communications protocol over a 4 wire RS-485 network.

The DLC is designed to simplify and automate the calibration of pump flow and analog signal. Flow calibration uses on-screen prompting, automated pump operation and automatic curve fitting to eliminate the need for stop-watches, calculators and reduces the possibility of human error. Analog signal calibration is also accomplished by simple key-pad entry. It includes real-time display of signal levels.

This eliminates the need for external meters.

The DLC readily accepts PULSAlarm leak detection, Level-Input detection or Remote Start/Stop station inputs that can be configured to stop the pump and/or activate an alarm relay.



THE REMOTE START/STOP CANNOT BE CONFIGURED TO ACTIVATE THE ALARM RELAY.

Failures are time and date stamped into memory for later retrieval. Other diagnostics include analog signal failure and line power failure monitoring. These are also time and date stamped and may be preset to control stroke position or motor status upon detection of a failure.

Security password protection may be activated to prevent tampering. All settings and diagnostics have a battery back-up for up to 10 years in the absence of power.

The DLC is available in any combination of 120/240 VAC, 50/60Hz. Protection exists to prevent damage against over or under voltage conditions in the event the wrong power line source is used.

1.2 DLC Standard Features

- Manual Stroke Length Control
- AC Pump Motor On/Off Control
- Keypad
- Back-lit 2 line 16 character LCD display
- NEMA 4X Enclosure
- One 4-20mA input for stroke length control
- One 4-20mA output
- MODBUS RS-485 Serial Communications
- 10-Year Battery Backed Clock
- Solid State Alarm Relay
- Level Input/Remote Start-Stop Inputs
- PULSAlarm Leak-Detection Interface
- Diagnostics

1.3 Options

- Operating Voltage/Frequency

2 Safety Considerations

The DLC is a sophisticated microprocessor based controller for use only with PULSAR diaphragm metering pumps. It yields tremendous control capacity – electrical, mechanical and (in conjunction with the PULSAR pump) hydraulic in nature. In consideration of SAFETY, the user should be mindful of this relative to his/her safety, that of co-workers and of the process environment. Consider the following prior to the installation and operation of a DLC controlled PULSAR metering pump.

- Read and understand all related instructions and documentation before attempting to install or maintain this equipment
- Observe all special instructions, notes, and cautions.
- Act with care and exercise good common sense and judgment during all installation, adjustment, and maintenance procedures.
- Ensure that all safety rules, work procedures, and standards that are applicable to your company and facility are followed during the installation, maintenance, and operation of this equipment.

2.1 General Safety

The DLC was designed as a motor on/off controller and stroke length position actuator for operation solely with the PULSAR metering pump. Use for any other application is considered unsafe and voids all certification markings and warranties.

2.2 Explosive Atmosphere Safety



EXPLOSION HAZARD -- DO NOT PERFORM INSTALLATION, CALIBRATION, OR MAINTENANCE OF ANY KIND ON THIS DEVICE WHILE CIRCUIT IS LIVE AND/OR THE AREA IS KNOWN TO BE HAZARDOUS.

Under expected operating conditions, and with the proper marking, this equipment is suitable for use in:

1. Class I, Division 2, Groups A, B, C, D Hazardous Locations;
2. Class 1, Zone 2, Groups IIC
3. Non-hazardous locations only

This equipment is suitable for use in Class I, Division 2, Groups A, B, C, and D or non-hazardous locations only.



EXPLOSION HAZARD -- DO NOT DISCONNECT EQUIPMENT UNLESS POWER HAS BEEN REMOVED OR THE AREA IS KNOWN TO BE NON-HAZARDOUS.

EXPLOSION HAZARD – SUBSTITUTION OF ANY COMPONENTS MAY IMPAIR SUITABILITY FOR CLASS I, DIVISION 2.



EXPLOSION HAZARD – DO NOT REMOVE OR REPLACE FUSES UNLESS POWER HAS BEEN DISCONNECTED OR THE AREA IS KNOWN TO BE FREE OF IGNITIBLE CONCENTRATIONS OF FLAMMABLE GASES OR VAPORS.

2.3 Electrical Safety

The DLC can be considered an industrial stroke length controller with an integrated pump motor on/off controller. Improper application and use can be hazardous. You are solely responsible for its use.

The DLC's electrical installation must conform to all relevant electrical codes. Installation and electrical maintenance must be performed by a qualified electrician.

Before installing or servicing this device, all power must be disconnected from the source at the main distribution panel. Certain calibration functions must be completed while the electronic section of the unit is exposed and power is applied to the unit, be certain to ensure that proper procedures are followed and that fingers, tools, and wiring do not contact exposed circuitry and components.

The DLC emits electro-magnetic energy and generates radio frequency interference. Its use is restricted to industrial applications. The user bears all responsibility for shielding this energy/interference.

2.4 Fire Safety

US & Canada Only

In case of electrical fire, use a Class C fire extinguisher. Fire extinguishers with a Class C rating are suitable for fires in “live” electrical equipment. Never use water to extinguish a Class C fire.

Class C fires involve electrical equipment, such as appliances, wiring, circuit breakers and outlets. Never use water to extinguish class C fires - the risk of electrical shock is far too great! Class C extinguishers do not have a numerical rating. The C classification means the extinguishing agent is non-conductive. This class is typically represented by a geometric symbol (blue circle).

Always refer to your country's occupational, health & safety regulations to ensure the correct fire extinguisher classification.

2.5 Mechanical Safety

When properly installed, the device has only one externally accessible moving part – the hand adjustment knob. This component is under computer control and as such may actuate without warning. Care should be taken to keep loose clothing away from this component. Hands and fingers should be kept clear while the knob is turning under DLC control.

The DLC was designed to be service free. It contains no user-maintainable components. Removal of the entire DLC as an assembly from the pump is permissible. Do not disassemble the DLC enclosure unless instructed to do so in this manual. Evidence of disassembly shall void the warranty.

2.6 Hydraulic Safety

Thoroughly review and adhere to the contents of the PULSAR Installation, Operation, Maintenance and Instruction manual, for hydraulic installation of your PULSAR metering pump. As a microprocessor-controlled device, the DLC may activate the pump motor without warning – generating hydraulic pressure and fluid flow. Care should be taken to protect both users and systems should the pump activate.

2.7 Liability Exclusion

Pulsafeeder, Inc. is unable to monitor the observance of the instructions given in this manual, nor verify the actual working conditions and installation of the equipment, the correct operation and maintenance of the equipment and accessories. An incorrect installation, or misuse of the equipment, may cause serious damage and may pose a danger to persons or property. Any anomalies must be reported to the maintenance supervisor.



ATTEMPTS TO DISASSEMBLE, MODIFY OR TAMPER IN GENERAL BY UNAUTHORIZED PERSONNEL WILL VOID THE GUARANTEE AND WILL RELEASE PULSAFEEDER, INC. FROM ANY LIABILITY FOR DAMAGE CAUSED TO PERSONS OR PROPERTY RESULTING FROM SUCH ACTIONS.

Pulsafeeder, Inc. is considered released from any liability in the following cases:

- improper installation;
- improper use of the equipment by non-professional or inadequately trained operators
- use not in compliance with regulations in the Country of use;
- lack of maintenance or improperly performed;
- use of non-original spare parts or incorrect parts for the model in question;
- total or partial failure to observe the instructions;
- exceptional environmental events.

2.8 Pump Suitability to Site of Installation

Essential safety requirements against explosion hazard in dangerous areas are regulated by European directives 94/9/CE dated 23rd of March 1994 (concerning equipment and devices)

Upon equipment receipt, verify that pumps have not received any damage due to transportation and are complete with every eventual accessory. In case anomalies or damages are discovered prior to installation, please contact PULSAFEEDER, INC. Technical Service.

The following standards apply to this product:

- ISA 12.12.01-2013
- UL 840
- UL 508
- CSA C22.2 No. 14-13

3 Transport and Inspection

3.1 Consignment receipt and un-packaging

Immediately after receipt of the equipment it must be checked against the delivery/shipping documents for its completeness and that there has been no damage in transportation.

Check any crate, boxes or wrappings for any accessories or spare parts that may be packed separately with the equipment or attached to side walls of the box or equipment.

Each product is marked with a unique serial number. Check that this number corresponds with the documentation, and always reference this number in correspondence as well as when ordering spare parts or accessories.

Shortages or damage should be reported immediately to the carrier and your Pulsafeeder Representative.

3.2 Handling

Boxes, crates, pallets or cartons may be unloaded using fork lift vehicles or slings dependent on their size and construction.

3.3 Lifting

A crane must be used for all controller/pump sets in excess of 25 kg (55 lb). Fully trained personnel must carry out lifting, in accordance with local regulations.

Slings, ropes and other lifting gear should be positioned where they cannot slip and where a balanced lift is obtained.

3.4 Recycling and end of product life

This device is RoHS compliant, and should be disposed of in accordance with current regulations.

Make sure that hazardous substances are disposed of safely and that the correct personal protective **equipment is used. The safety specifications must be in accordance with the current regulations at all times.**

4 Storage Instructions

The DLC can be successfully stored for extended periods. The key to this success is temperature and humidity control.

4.1 Storage Length

4.1.1 Short Term (0 - 12 months)

The DLC should be stored in a temperature and humidity controlled environment. It is preferable to keep the temperature constant in the range of -18 to 40° Celsius (0 to 104° Fahrenheit). The relative humidity should be 0 to 90% non-condensing.



THE ADJUSTMENT KNOB SHOULD BE ROTATED IN ALTERNATE DIRECTIONS BY HAND ONE FULL REVOLUTION EVERY SIX MONTHS.

If the DLC is installed on the pump, it should not be removed during this period – provided the above conditions can be applied to the pump as well. If the DLC is removed from the pump, it should be stored in the same pump mounted orientation. After removal of the DLC from the PULSAR metering pump, seal the eccentric box opening with a dust and moisture proof material. If the DLC was shipped in its own carton, it should be stored in that carton.

4.1.2 Long Term (12 months or more)

Storage of the DLC for periods of longer than twelve months is not recommended. If extended storage is unavoidable the DLC should be stored in accordance with those conditions stipulated for Short Term Storage. In addition, a porous bag of 85g (3 oz) silica gel or similar desiccant should be placed beneath the wiring access cover. The cover should be re-installed to seal the desiccant within the enclosure. The three conduit connections must be tightly capped. Inspect the unit carefully for any signs of damage and remove the desiccant before placing it into operation.



SPECIAL NOTE FOR LONG-TERM STORAGE:

IF AC INPUT POWER HAS NOT BEEN APPLIED TO THE DLC FOR A PERIOD GREATER THAN 12 MONTHS, THE CONTROLLER MUST BE PREPARED FOR OPERATION. THE DLC SHOULD HAVE AC POWER APPLIED AT THE INPUT FOR A PERIOD OF 8 HOURS BEFORE PLACING PUMP INTO NORMAL OPERATION. REFER TO INSTALLATION AND WIRING SECTION FOR AC POWER CONNECTION INSTRUCTIONS.

5 Installation

5.1 Location



REVIEW THE SAFETY SECTION PRIOR TO INSTALLING THE DLC. IT CONTAINS INFORMATION REQUIRED TO PROPERLY INSTALL AND OPERATE THE DLC IN AN INDUSTRIAL ENVIRONMENT.

The site selected for the installation of your DLC is largely dependent on that of the PULSAR metering pump. Review the PULSAR Installation Operation Maintenance Instruction Manual provided with your PULSAR metering pump. It details system related issues that are important to proper operation of the PULSAR metering pump.

Consider the following DLC related issues when selecting a site.

- The DLC should be mounted in an area where the operator has access to the front of the unit and a clear view of the display panel and keyboard.
- Avoid locations where the DLC would be subjected to extreme cold or heat.
- Note the warning statement on the next page. The installation of this device must comply with national, state and local codes.

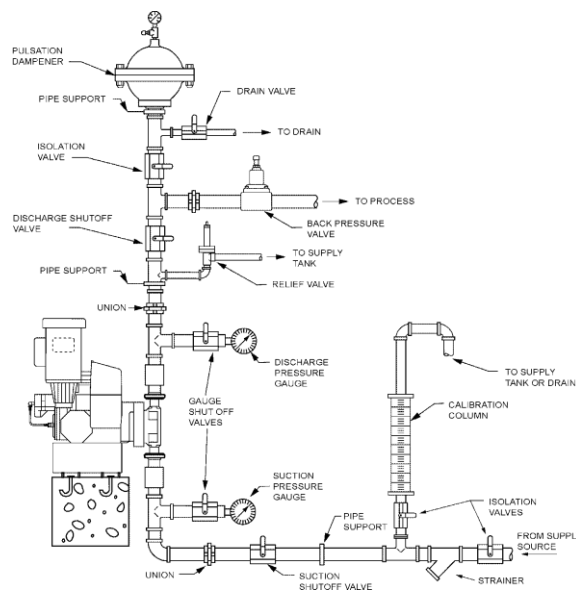

Figure 1 – Typical Installation



AVOID LOCATIONS WHERE THE DLC WOULD BE SUBJECTED TO EXTREME COLD OR HEAT [LESS THAN -18°C (0°F) OR GREATER THAN 40°C (104°F)] OR DIRECT SUNLIGHT. FAILURE TO OBSERVE THIS WARNING COULD DAMAGE THE DLC AND VOID ITS WARRANTY.

5.2 Installation Notes

1. The DLC is a microprocessor based controller that uses electro-static sensitive CMOS components. Do not make any electrical connections (high or low voltage) without adequately grounding the DLC and the worker to eliminate an electro-static charge between the two. A conductive wrist strap worn by the worker and attached to the DLC enclosure is adequate to satisfy this requirement.
2. Calibration is an important element of successful DLC operation. Permanent installation of a calibration column as depicted in **Figure 1** is strongly recommended.
3. Conduit connections can carry fluids and vapors into the DLC causing damage and void the warranty. In accordance with any applicable codes provide sealed entries and conduit drains near the point of entry as required. Care should be taken when installing conduit to protect against fluid/vapor entry. If necessary, provide sealed entries or conduit drains near the point of entry.

5.3 Electrical Wiring

The DLC has many advanced features that may make wiring the unit appear complicated. Wiring is actually very simple – one high-voltage connection is all that is required to take advantage of a majority of the DLC's features. It is highly recommended that you take a step-by-step approach to wiring and confirming proper DLC operation:

1. Make the high-voltage connection. These will allow you to operate the DLC and attached PULSAR pump.
2. Power-up and test the DLC to confirm the connections and check for proper operation.
3. Power-down the DLC.
4. Decide which low-voltage Inputs (e.g., 4-20mA in) will be used and make those connections.
5. Power-up and test the DLC to confirm the connections and check for proper operation.
6. Power-down the DLC.
7. Decide which low-voltage outputs (e.g., 4-20mA out) will be used and make those connections.
8. Conduct a final power-up and test the DLC to confirm the connections and check for proper operation.
9. Go to the Section 6: Startup Instructions for details on how to perform the power-up tests.

5.3.1 Getting Started

The field wiring of the DLC is accomplished through a rear access cover at the back of the unit – near the PULSAR gearbox and motor. The access panel is opened by removing the 4 retaining screws (Phillips head screw driver required). Removal reveals the Field Wiring Board (refer to **Figure 2**).

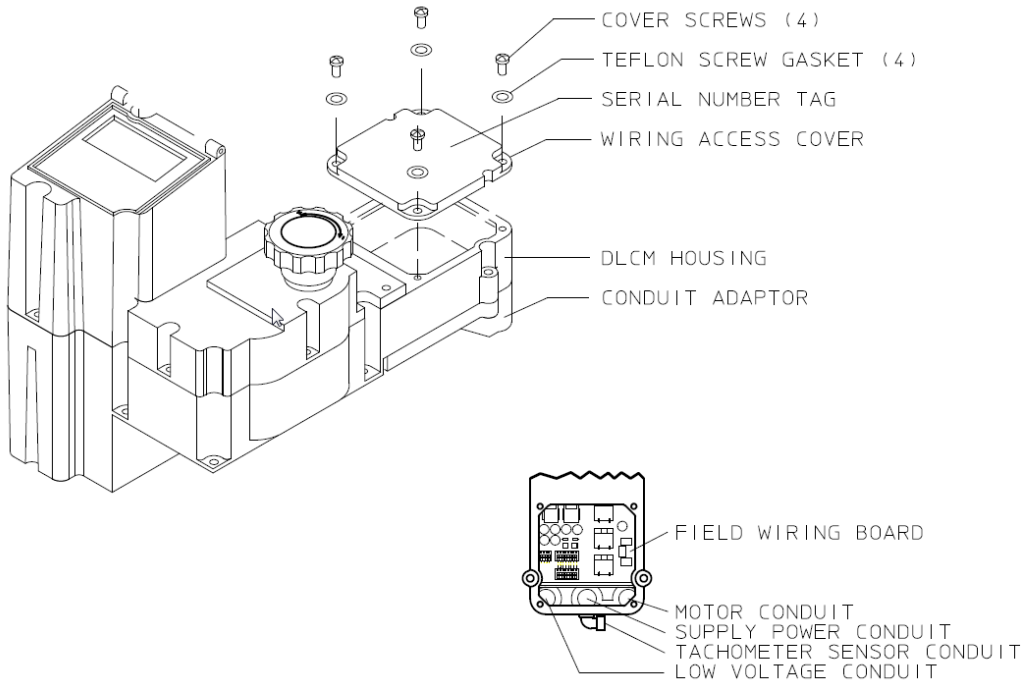

Figure 2 – Accessing the Field Wiring Board



TIP

THE FIELD WIRING ACCESS COVER HAS THE SERIAL NUMBER TAG ON IT. KEEP THE COVER WITH THE DLC IT WAS REMOVED FROM. THE DLC IS MARKED INTERNALLY WITH THE SERIAL NUMBER. THE INTERNAL MARKING WILL BE USED FOR WARRANTY CLAIMS.

The Field Wiring Board (refer to **Figure 2**) contains wiring blocks for making all of the electrical connections. It is mechanically attached to the Conduit Adapter. The adapter in conjunction with the Field Wiring Board forms a modular connector or plug. This allows the DLC to be removed from the PULSAR unit without disturbing the conduit connections.



WARNING

REMOVE THE CONDUIT ADAPTER AND FIELD WIRING BOARD FOR DLC REPAIR/REPLACEMENT PURPOSES ONLY (REFER TO SECTION 12: BASIC REPAIRS) FOR FURTHER INFORMATION.

5.3.2 Finding your way around the Field Wiring Board

The electrical connections are segregated on the Field Wiring Board. The high-voltage connections are on the right-half side while the low-voltage connections are on the left. Refer to **Figure 3, Field Wiring Board** for specific connection and fuse locations.

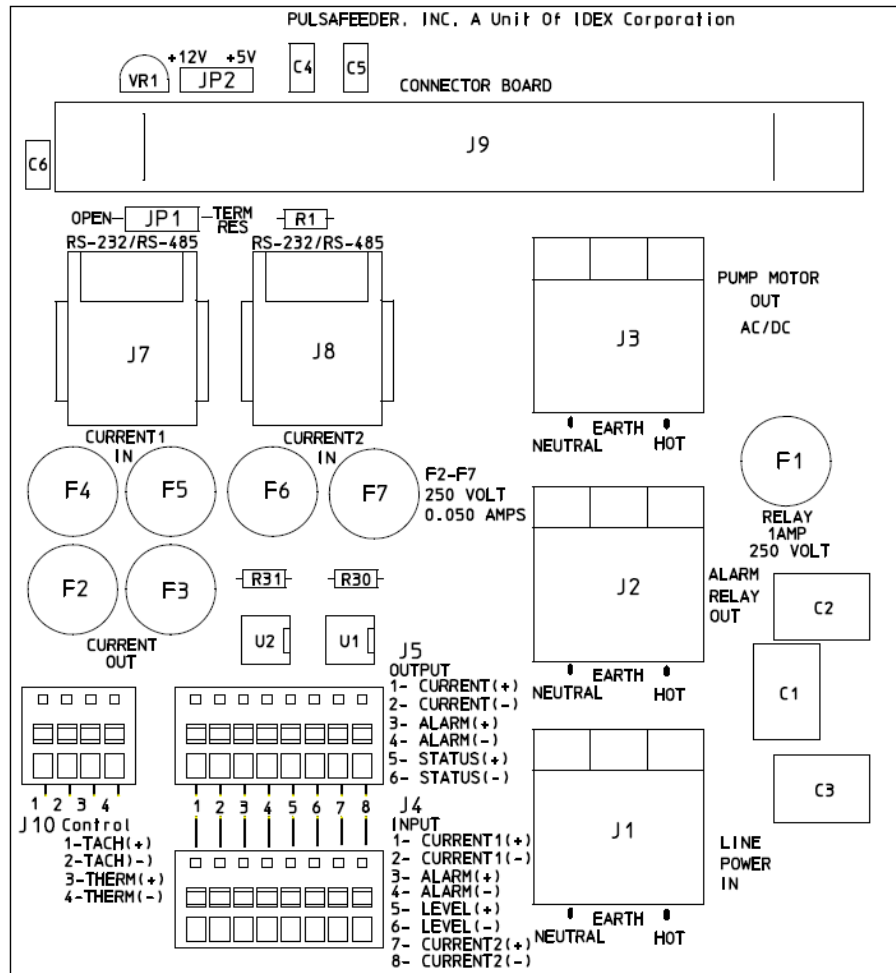

Figure 3 - Field Wiring Board

5.4 High-Voltage Connections

There are only three high-voltage connections to be made on the DLC: supply power (J1), PULSAR motor load (J3), and Alarm Relay Load (J2). Only the supply power and PULSAR motor load connections are required. Refer to **Figure 4** for connection location.

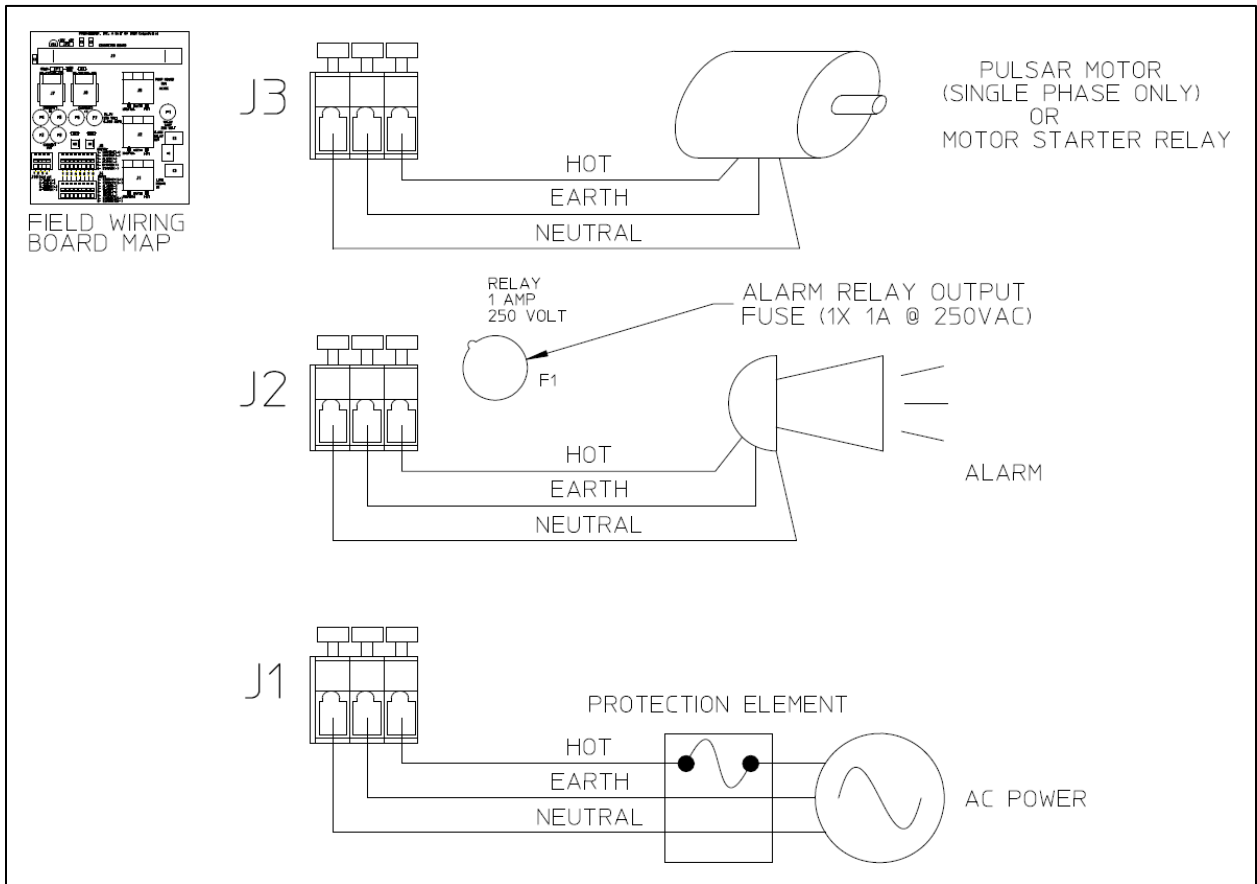

Figure 4 – High-Voltage Connections

5.4.1 Supply Power



THE DLC REQUIRES ONE CONNECTION TO AN EXTERNAL POWER SOURCE. IT USES THIS SAME CONNECTION TO POWER ITS OWN SUPPLY, THE DC PUMP MOTOR AND THE ALARM RELAY OUTPUT. YOU MUST TAKE THESE EXTERNAL LOADS INTO CONSIDERATION WHEN SIZING THE BRANCH CIRCUIT.

The DLC with attached PULSAR motor is not fuse protected. You are responsible for correctly sizing the protection element (i.e., fuse or circuit breaker at the distribution panel). Use the work sheet on the next page for correctly sizing the branch protection element.

The DLC, with an attached pump motor and alarm load, should be connected to its own branch circuit. Size the supply wire and protective element according to local code requirements. Use 14 AWG, 105°C insulation wire or better. Attach the supply to the J1 terminal block labeled 'LINE'

POWER IN'. Make 3 connections: Neutral, Earth (ground) and Hot as labeled.

15VAC +/- 10%	50/60 Hz	230VAC +/- 10%	50/60 Hz
Device	Current Requirement (Amp)	Device	Current Requirements (Amp)
DLC	1A (1A Max.)	DLC	.5A (.5A Max.)
Pump Motor*	+ (8A Max.)	Pump Motor*	+ (4A Max.)
Alarm Relay*	+ (1A Max.)	Alarm Relay*	+ (1A Max.)
Total**	=	Total**	=
* In-rush current requirements should be considered. All values RMS.			
** Calculation is for guideline purposes only. User must consult local electrical codes when sizing branch circuits. Protection must not exceed 10Amps RMS at 115VAC or 5.5Amps RMS at 230VAC.			

Branch Circuit Protective Element Sizing Worksheet

The operating voltage and frequency of the DLC are factory configured – an internal motor and capacitor are sized according to voltage and frequency. If the power supplied to the unit does not match the factory configuration, the DLC will display either an {OVER VOLTAGE} or {UNDER VOLTAGE} diagnostic message on power-up. This is possible because the microprocessor and display are powered by a switching power supply. It detects the incoming power and self-regulates its output. This power supply is protected by a 7.4 Joule surge suppression device. The microprocessor will not operate the internal stroke adjustment motor, potentially causing damage, until the voltage problem is corrected.



HIGH-VOLTAGE CIRCUITS (E.G., BRANCH) SHOULD BE RUN IN SEPARATE CONDUIT. DO NOT COMBINE HIGH-VOLTAGE (I.E., GREATER THAN 100VAC) LINES AND LOW-VOLTAGE (I.E., LESS THAN 32VDC) LINES IN A COMMON CONDUIT! FAILURE TO COMPLY WILL RESULT IN ELECTRICAL INTERFERENCE THAT MAY RESULT IN IMPROPER (AND POSSIBLY UNSAFE) OPERATION.

5.4.2 PULSAR Pump Motor



In most cases the DLC is supplied with a factory installed AC motor. If it was not supplied then connect the AC Pump Motor the J3 terminal block labeled 'PUMP MOTOR OUT AC' (Use 14 AWG [2.1mm²], 105C insulation wire size or larger.) The pump motor must be selected and wired to operate at the DLC supply voltage (i.e., if the power supplied to J1 is 115VAC 60Hz, then the motor must operate on 115VAC at 60Hz).



THE DLC USES SOLID-STATE RELAYS FOR ITS HIGH-VOLTAGE OUTPUTS (I.E., MOTOR AND ALARM). IN THE 'OFF' STATE, THESE DEVICES TYPICALLY LEAK 20-30MA OF CURRENT AT THE SUPPLY VOLTAGE TO THE ATTACHED DEVICE (OR TERMINAL BLOCK)! THE SUPPLY POWER MUST BE DISCONNECTED AT THE MAIN BEFORE WORKING ON ELECTRICAL CONNECTIONS OR ANY MOVING PUMP COMPONENTS (E.G., MOTOR, GEAR TRAIN, ETC.).



DOUBLE CHECK ALL CONNECTIONS TO CONFIRM GOOD ELECTRICAL CONTACT BETWEEN THE TERMINAL BLOCK CLAMPS AND BARE WIRE. MAKE SURE THE CLAMP IS ON THE WIRE, NOT THE INSULATION. INSURE THAT BARE WIRE IS NOT FRAYED AND DOES NOT RISE ABOVE THE DIVIDERS BETWEEN TERMINALS.

If the PULSAR pump motor is controlled by a separate Variable Speed Drive (e.g., VFD), the Variable Speed Drive's Start/Stop must be controlled by the DLC. This can be accomplished through the use of an external relay with a high voltage coil (e.g., 120VAC) activated by J3. Wire the PULSAR motor and relay output (contact) to the Variable Speed Drive in accordance with the Variable Speed Drive manufacturer's instructions.

If the PULSAR pump motor operates at a voltage that is different than that supplied to the DLC or

is a three-phase motor, then a motor starter must be used. Wire the motor starter relay to J3. Wire the PULSAR motor to the motor starter in accordance with the starter manufacturer's instructions.

DAMAGE MAY OCCUR TO THE DLC IF THE PULSAR PUMP MOTOR IS NOT WIRED AND COMMUNICATING WITH THE DLC.

5.4.3 Alarm Relay

The Alarm Relay is an output that is configured by the operator. Refer to **Section 7: General Operation** for specific instructions on how to activate the Alarm Relay. The Alarm Relay Load must not exceed 1 Amp at rated voltage. Connect the Alarm load to the J2 terminal block labeled 'ALARM RELAY OUT.' Use 14 AWG wire size or larger. Make three connections: Neutral, Earth (ground) and Hot as labeled.

5.5 Low-Voltage Input Connections

There are two types of low-voltage inputs: Current (e.g., 4-20mA) and Dry Contact. The Low-Voltage Input connection block is labeled J4 'INPUT' (refer to **Figure 5**). It contains four pairs of inputs: Current 1, Alarm, Level and Current 2.

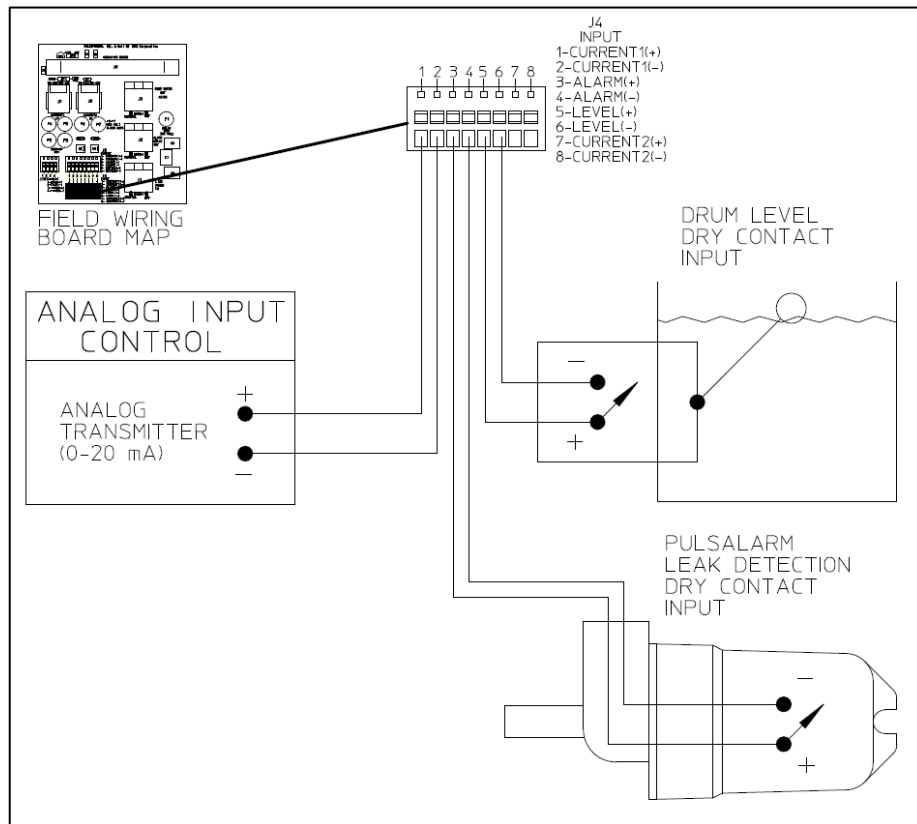

Figure 5 – Low-voltage Input



THE DRY CONTACT INPUTS ARE SELF-POWERED. SUPPLY ONLY A MECHANICAL SWITCH CLOSURE TO ACTIVATE. DO NOT ATTACH EXTERNALLY POWERED CIRCUITRY.

THE WIRE USED TO CONNECT LOW-VOLTAGE INPUTS, AND SERIAL COMMUNICATIONS SHOULD BE RUN IN A CONDUIT SEPARATE FROM THE HIGH-VOLTAGE POWER. DO NOT COMBINE HIGH-VOLTAGE (I.E., GREATER THAN 100VAC) LINES AND LOW-VOLTAGE (I.E., LESS THAN 32VDC) LINES IN A COMMON CONDUIT! FAILURE TO COMPLY WILL CAUSE ELECTRICAL INTERFERENCE THAT MAY RESULT IN IMPROPER (AND POSSIBLY UNSAFE) OPERATION.

5.5.1 Analog Inputs

The DLC can accept one analog input signal. This signal controls the pump's flow. The Analog Input is used to control pump stroke length.

The Analog input accepts current inputs in the range of 0 to 25mA (e.g., 4-20mA) provided the 'span' (the difference between the High and Low value), is greater than 2mA. Voltage signals in the 0-5 volt range are accepted but displayed as current during Analog Input calibration.

Split-ranging, reverse acting, and ratio control are accomplished in the calibration routine in **Section 7: General Operation**. No hardware adjustments are required. The channels are electrically isolated, surge protected and fused for protection. The inputs are designed to avoid damage in the event high-voltage is inadvertently applied.

To make the Stroke Length Control connection, use 0.32mm² – 0.52mm² (22-20 AWG) wire for hookup. Attach the analog signal generated by an external device (e.g., PLC) to the connection points labeled '1-CURRENT1(+)' and '2-CURRENT1(-)' on the J4 terminal block labeled 'INPUT' (refer to **Figure 5**). Attach the Positive lead to position 1 and the Negative lead to position 2.

Position indicators are printed on the circuit board above the terminal. The DLC will provide approximately 200 ohms of resistance to a current loop. The Analog Input is isolated from all other inputs, outputs and earth ground. Follow the instructions in **Section 7: General Operation** for Analog Input signal calibration and setup.

5.5.2 Alarm Input

The Alarm Dry Contact Input is designed to operate with the PULSAlarm leak-detection option. It is software configurable to generate an alarm, activate the alarm relay and/or shut down the PULSAR motor. The input is internally powered – only a mechanical switch closure is required for activation. Use 0.32mm² – 0.52mm² (22-20 AWG) wire. Attach one side of the switching device to the position labeled '3-ALARM(+)' and the other side to the position labeled '4-ALARM(-)' of connector J4-INPUT (refer to **Figure 5**). A resistance of 15K ohms or less is required across the two connections for proper detection. Follow the instructions in **Section 7: General Operation** for Alarm Input (Leak-Detection) software setup.

5.5.3 Level Input (Remote Start/Stop)

The Level Dry Contact Input is designed to monitor a single-point Level Input sensor and generate an alarm, activate the alarm relay and/or shut down the PULSAR motor. It can also be used with a Remote Start/Stop station (Dry Contact switch) to start and stop the pump's motor. The input is internally powered, only a mechanical switch closure is required for activation. Use 0.32mm² – 0.52mm² (22-20 AWG) wire. Attach one side of the switching device to the position labeled '5-LEVEL(+)' and the other side to the position labeled '6-LEVEL(-)' of connector J4-INPUT (refer to **Figure 5**). A resistance of 15K ohms or less across the two terminals is required for proper detection. Follow the instructions in **Section 7: General Operation** for Level / Start-Stop setup.

5.6 Low-Voltage Output Connections

There are two types of low-voltage outputs: Analog (e.g., 4-20mA) and Transistor based Dry Contact. The Low-Voltage Output connection block is labeled J5 'OUTPUT' (refer to **Figure 6**). It contains three- pairs of outputs: Current, Alarm and Motor Status/Stroke.



THE TRANSISTOR BASED DRY CONTACT OUTPUTS ARE OPTICALLY ISOLATED. TO ACHIEVE TOTAL ISOLATION, THEY ARE NOT SELF-POWERED. THE EXTERNAL DEVICE MUST SUPPLY AND DETECT A RETURN VOLTAGE LEVEL (32VDC MAX).



THE WIRE USED TO CONNECT LOW-VOLTAGE INPUTS, OUTPUTS AND SERIAL COMMUNICATIONS SHOULD BE RUN IN A CONDUIT SEPARATE FROM THE HIGH-VOLTAGE POWER. DO NOT COMBINE HIGH-VOLTAGE (I.E., GREATER THAN 100VAC) LINES AND LOW-VOLTAGE (I.E., LESS THAN 32VDC) LINES IN A COMMON CONDUIT! FAILURE TO COMPLY WILL RESULT IN ELECTRICAL INTERFERENCE THAT MAY RESULT IN IMPROPER (AND POSSIBLY UNSAFE) OPERATION.

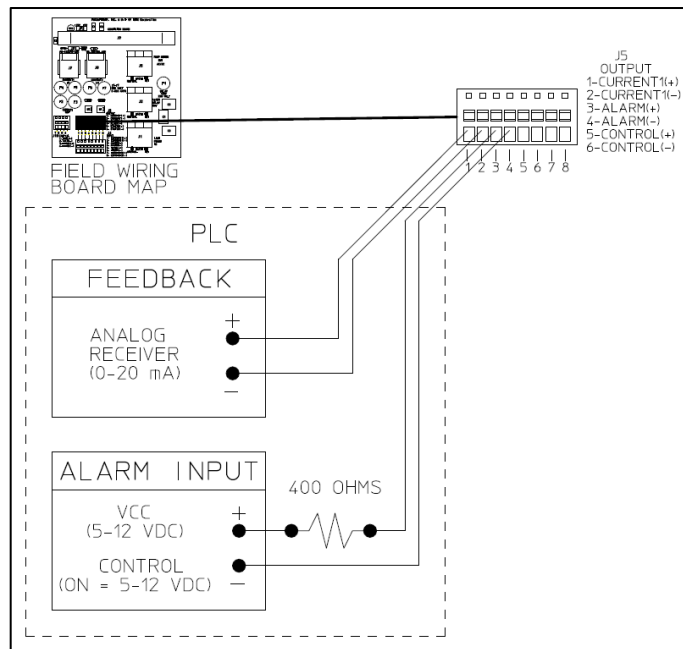

Figure 6 – Low-voltage Output

5.6.1 Current Output

The Current Output is calibrated to source current in the 0 to 20mA range (e.g., 4-20mA). The output can be calibrated for reverse acting and split ranging and control. Refer to **Section 7: General Operation, Calibration** for further details.

Current Output is used to control slave devices (e.g., DLC's, ELMA's, PULSAMATIC's, etc.) or to fulfill closed loop system requirements. Attach the connection points labeled '1-CURRENT (+)' and '2- CURRENT (-)' on connector J5-OUTPUT (refer to Figure 6) to the external device. Use $0.32\text{mm}^2 - 0.52\text{mm}^2$ (22-20 AWG) wire. Attach the Positive lead to position 1 and the Negative lead to position 2. The analog output will drive against a maximum load of approximately 700 ohms. Thus, a single DLC Analog Output could be used to drive two slave DLC's. They, in turn, could each drive two additional slaves. The Analog Output is isolated from all other inputs, outputs and earth ground. Follow the instructions in **Section 7: General Operation, Analog Output Signal Calibration**.

5.6.2 Alarm Dry Contact Output

The Alarm output is a solid state transistor closure. It indicates the present state of the alarm relay output. If the Alarm Relay is on, the Alarm Dry Contact will be closed. If the Alarm Relay is off, the Alarm Dry Contact will be open. It is commonly used to indicate an alarm status to external control equipment (i.e., PLC, PC or other Manual controllers). Refer to **Figure 6**.



VCC (+5VDC) AND GROUND ARE PROVIDED ON TERMINALS 7 AND 8 OF CONNECTOR J5. A 250 OHM RESISTOR FROM TERMINAL '7-VCC' TO TERMINAL '3-ALARM(+)' WILL CAUSE A +5VDC SIGNAL TO APPEAR BETWEEN TERMINALS '4-ALARM(-)' AND '8-DCGND' WHEN THE ALARM RELAY IS ON. THIS TECHNIQUE IS ONLY RECOMMENDED IF THE INPUT ON THE EXTERNAL DEVICE IS ISOLATED FROM ALL OTHER INPUTS, OUTPUTS AND GROUNDS.

An opto-coupler is used to achieve total isolation of this output. As such, the external control equipment must generate the supply on the positive output and detect the return of that signal from the DLC. In a typical application, use 0.32mm² – 0.52mm² (22-20 AWG) wire to attach the terminal labeled '3-ALARM(+)' – the collector terminal – to the external equipment's logic supply. Connect the terminal labeled '4-ALARM(-)' – the emitter terminal – to the positive input of the equipment. The negative input of the equipment should be connected to its isolated ground. A series resistance of 400 ohms is recommended – especially when sinking current (e.g., a photo-diode of an opto-isolator). The Alarm output cannot be separately configured in the software, it follows the Alarm Relay output.

5.6.3 Run Status or Stroke Counter

The Status output can be configured through software to indicate that the pump motor status (on/off), to generate a pulse with every pump stroke (for use with an external stroke counter), or to indicate the Operating Mode (Manual, Analog or MODBUS). The factory default for this output is to indicate Pump Motor Status.



Note, the Stoke output is not in phase with the pump stroke but has a 50% duty cycle (e.g., the output is ON for half of the stroke and OFF for the other half.).

An opto-coupler is used to achieve total isolation of this output. As such, the external control equipment must generate the supply on the positive output and detect the return of that signal from the DLC. In a typical application, use 0.32mm² – 0.52mm² (22-20 AWG) wire to attach the terminal labeled '5-STATUS(+)' – the collector terminal – to the external equipment's logic supply. Connect the terminal labeled '6-STATUS(-)' – the emitter terminal – to the positive input of the equipment. The negative input of the equipment should be connected to its isolated ground. A series resistance of 400 ohms is recommended – especially when sinking current (e.g., a photo-diode of an opto-isolator).



THERE IS ALSO AN INTERNAL STROKE COUNTER THAT IS RE-SETTABLE. REFER TO SECTION 7.2: MENU – DIAGNOSTICS, DIAG. MENU 11/11.

5.7 Serial Communications Input

The Serial Communications input is used to communicate digitally with the DLC. It allows remote control and, if so configured, can be used to replace the analog input and output to allow one or more DLC's to be slaved to a single DLC, DLCM, PLC, or PC master.

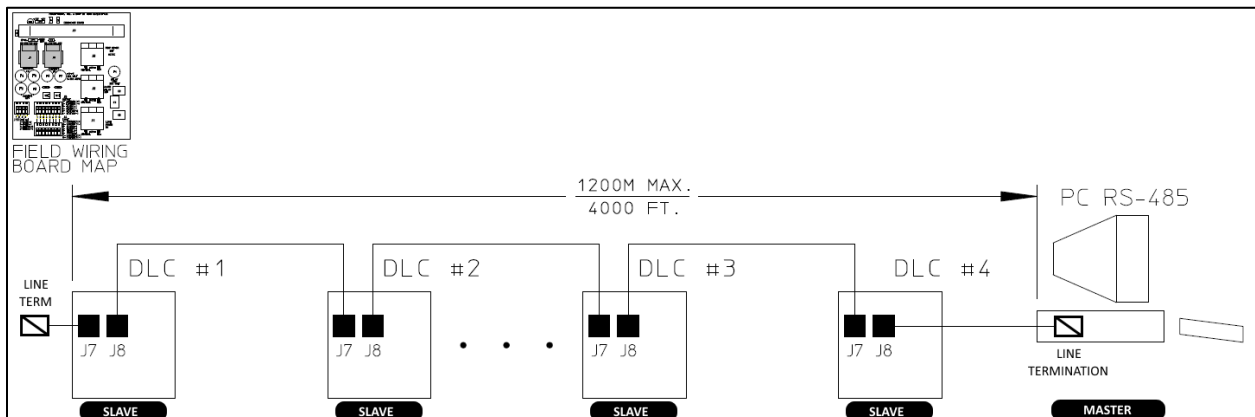

Figure 9 – Typical Serial Communications Connections

Use Belden™ Type 1590A data twist cable or equivalent. RJ-11 connectors (not supplied) are used to plug into jacks J7 & J8 (refer to **Figure 9**).

The DLC uses a 4-wire RS-485 network. This uses two wires for transmit and two wires for receive. The RS-485 specification limits the total network length to 1200M (4000 ft). Multiple device networks may also require termination at both the first and last device. For further details refer to **Section 8: Diagrams/Installation**.

5.7.1 Important Wiring Detail

5.7.1.1 Slave to Slave

When connecting two **Slaves**, the wiring is straight through. For example: Connect the transmit lines to the transmit lines and the receive lines to the receive lines (refer to the drawing below).

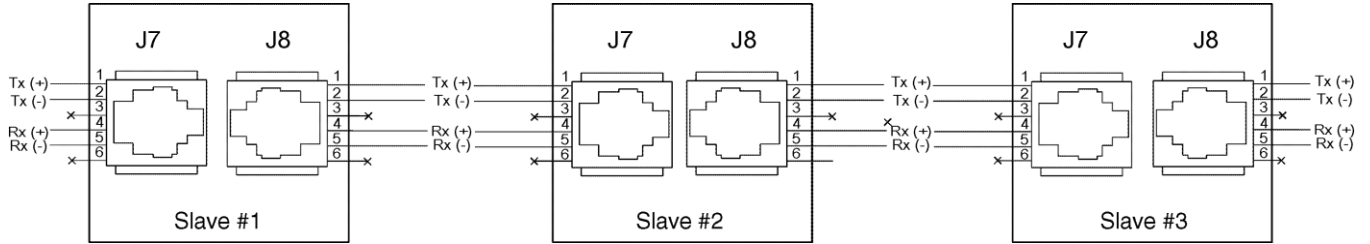

5.7.1.2 Master to Slave

When wiring between a **Master** and a **Slave**, the Transmit and Receive lines must be crossed. For example: Connect the transmit lines to the receive lines (refer to the drawing below).

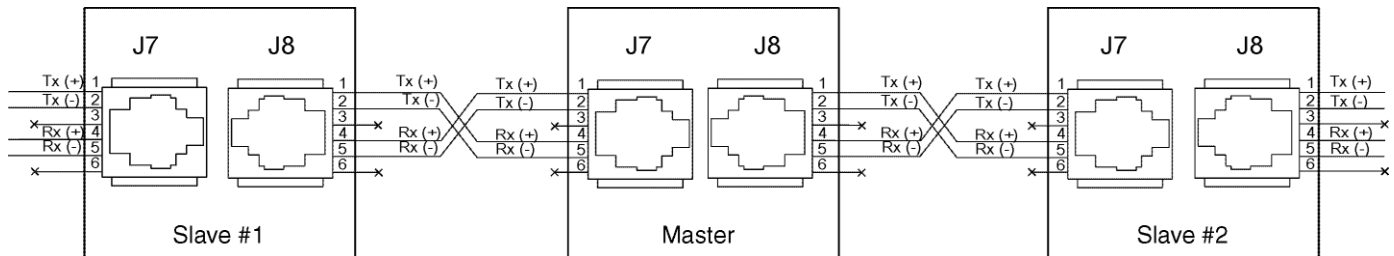

Figure 10 – Wiring Detail

5.8 Fuse Replacement

Although Fuse replacement is not a part of normal installation, it is possible that fuse failure will result from improper wiring. The DLC uses a total of 7 user replaceable fuses: 1 for the alarm relay output, 2 for each of the Current Input and Output Channels. The table below details fuse replacement information:

Designator	Function	Rating	Wickman P/N	Pulsafeeder P/N
F1	Alarm Relay	1A @ 250VAC	WK4048-ND	NP5300026-000
F2-7	Current I/O	50mA @ 250VAC	WK3022-ND	NP5300027-000

REPLACEMENT FUSE INFORMATION

Figure 11 details the location of these fuses on the Field Wiring Board.

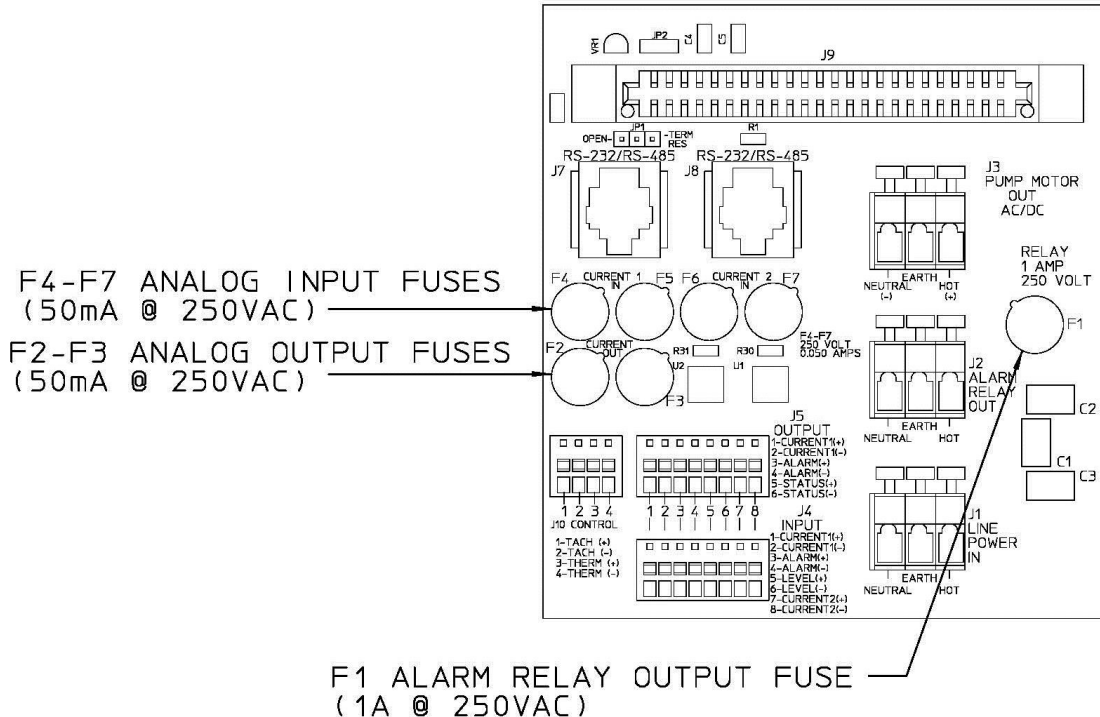

Figure 11 – Fuse Location.

The Internal DLC power supply is fused at 2 Amps. This fuse is not user serviceable. The DLC Stroke Length Adjustment Synchronous Motor is inherently protected. It can operate continuously in a locked rotor state. The DLC also monitors this motor's duty cycle to maintain a 50% balance between ON and OFF times. The serial ports and the Remote Run Status Output are protected by self-resetting current limit devices. These components are not user serviceable.

6 Startup Instructions

6.1 Overview

Once all electrical connections have been made, your DLC is ready for Startup. The following nine sections detail the procedures required to complete a DLC startup.



WHEN POWER IS SUPPLIED TO THE UNIT, LINE VOLTAGE IS PRESENT ON THE FIELD WIRING BOARD LOCATED AT THE BACK OF THE UNIT EVEN WHEN THE MOTOR IS OFF.



DURING STARTUP, IT IS NECESSARY TO RUN THE PUMP MOTOR. THIS WILL CAUSE FLUID TO DISCHARGE FROM THE PUMP. YOU ARE RESPONSIBLE FOR SAFELY DIVERTING FLOW FROM THE PUMP DURING STARTUP AND CALIBRATION.

6.1.1 User Interface Familiarization

There are four key elements that will be useful in starting-up the DLC:

1. Display
2. Keypad
3. Manual Adjustment Knob
4. Pump Motor

Refer to **Figure 12** to familiarize yourself with the location of these items before proceeding.

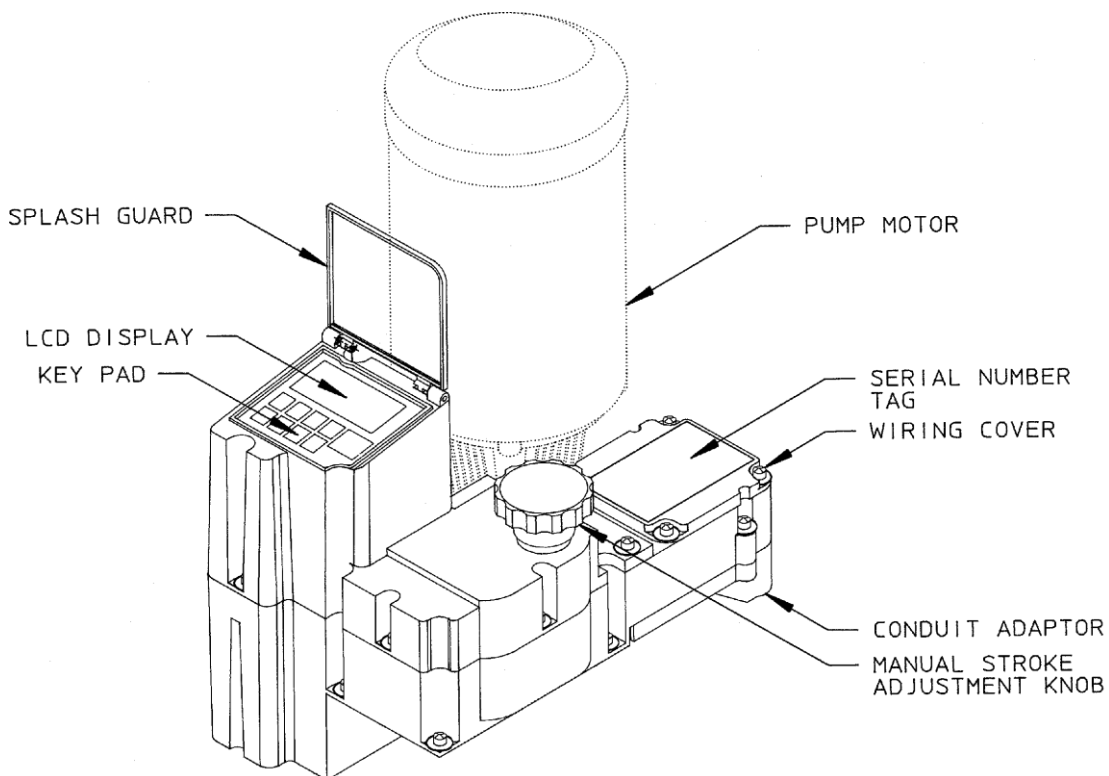

Figure 12 – Key DLC startup elements.

6.1.1.1 Display

This is a 2 line by 16 character alpha-numeric Liquid Crystal Display (LCD) located above the keypad. It is back-lit with a yellow-green light source for easy viewing in dark areas. Its contrast can be adjusted by using the keypad.

6.1.1.2 Keypad

The Keypad is a sealed 9-button membrane style input device. It is easy to use and will guide you quickly to specific functions. Refer to **Figure 13** to familiarize yourself with the function of each key before starting.

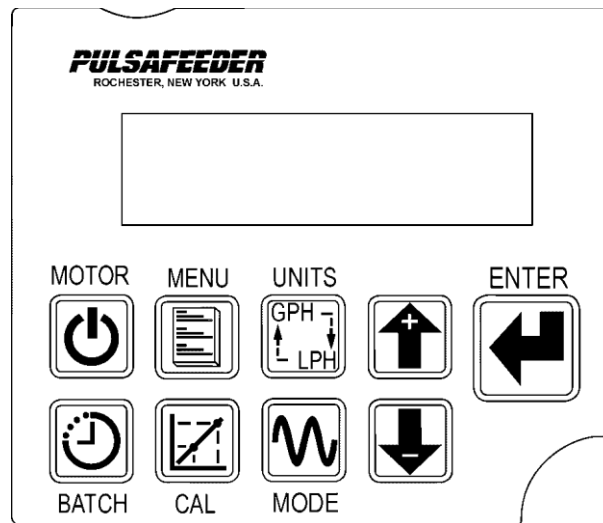

Figure 13 – Key Pad

- MOTOR** Press this key to Start the PULSAR motor or place it in stand-by.
- MENU** Press this key to access the Configuration Menu. Press the ARROW keys to scroll through the Configuration Menu Items. Press [MENU] a second time to exit the Configuration menu to the current operating mode (e.g., MANUAL MODE).
- UNITS** Press this key to cycle to the next flow unit type whenever a flow unit is displayed at the operating mode (e.g., MANUAL MODE).
- ARROWS** These keys are used to change values currently displayed on screen. Use [DOWN] to decrease the value and [UP] to increase it. Pressing both [UP] and [DOWN] simultaneously performs special editing and by-pass functions. This is described further in **Section 7: General Operation**.
- ENTER** Use this key to accept a flashing value or parameter and proceed to the next sub-menu screen.
- BATCH** This key is used to activate the [BATCH] processing menu. Press [BATCH] a second time to exit the Batch Setup function.
- CAL** Press [CAL] to activate the Calibration menu for Flow and Analog Signals. Press [CAL] a second time to exit the Calibration function.
- MODE** The [MODE] key is used to change the operating mode of the DLC. For example, press once to change from MANUAL to ANALOG. Press a second time to change from ANALOG to MODBUS. Press a third time to change from MODBUS back to MANUAL.

6.1.1.3 Manual Adjustment Knob

The manual adjustment knob is mechanically attached to the PULSAR stroke length adjustment mechanism. The DLC uses the shaft attached to this knob to make its automatic adjustments. Visually, the knob is a good indication of what the DLC is doing. For example, if the DLC is

increasing the pump stroke length – moving from 0 to 100% -- the knob will turn counter-clockwise until the desired position is achieved.

If you try to force the adjustment, the DLC will automatically react to adjust the position to the programmed setting. If you manually adjust the knob while performing a pump calibration, the calibration session will be terminated.

While in the Analog Signal or MODBUS Mode – any attempts you make to change the stroke setting using the Manual Control Knob to a value other than that specified by the remote signal will cause the DLC to make a correction.



THE MANUAL ADJUSTMENT KNOB SHOULD NOT BE ADJUSTED WHILE POWER IS REMOVED FROM THE DLC. IF THE KNOB IS MOVED WHILE THE DLC POWER IS OUT, UPON RE-STARTING THE DLC WILL DETECT THE MOVEMENT AND PERFORM A ZERO CALIBRATION.



WHEN THE DLC IS PERFORMING A ZERO CALIBRATION (THE DISPLAY WILL READ {CALIBRATING ZERO}), DO NOT TO TOUCH THE MANUAL ADJUSTMENT KNOB. DURING A ZERO CALIBRATION THE DLC IS SEARCHING FOR A HARD MECHANICAL STOP. ANY MANUAL INTERVENTION COULD CAUSE THE DLC TO INCORRECTLY DETECT THIS STOP. THIS WILL RESULT IN AN IMPROPER CALIBRATION.



YOU MAY NOTICE THAT WHEN ADJUSTING FROM A LOWER TO A HIGHER VALUE (E.G., 10% TO 20%) THE DLC APPEARS TO 'OVER-SHOOT' ITS DESTINATION AND REVERSE DIRECTION FOR APPROXIMATELY 1/16 OF A REVOLUTION. THIS BEHAVIOR IS NORMAL. THE DLC ALWAYS APPROACHES A NEW POSITION FROM THE SAME DIRECTION TO ELIMINATE BACKLASH IN THE STROKE ADJUSTMENT MECHANISM.

6.1.2 Check Wiring and Close Access Cover

Double check all of your electrical connections. Pay attention to polarity of all inputs and outputs – both low and high voltage. Additionally, insure that all clamp style terminals are clamping onto the bare conductor, not on its insulation.

Replace the wiring access cover and its 4 retaining screws with associated washers.



USE A SCREWDRIVER TO TIGHTEN THE RETAINING SCREWS EVENLY (14 in-lb / 1.6 N-M). FAILURE TO DO SO MAY CAUSE THE COVER TO LEAK AND VOID THE WARRANTY. THE SUPPLIED TEFLON WASHERS ARE REQUIRED TO PROPERLY SEAL THIS COVER. FAILURE TO REPLACE THESE COMPONENTS WILL VOID THE WARRANTY.

6.1.3 Confirm Correct Incoming Power

Check that the wiring access cover is on and tightened down. Whenever power is supplied to the DLC, the display's back-lighting will 'glow' with a yellow-green light. The presence of this back-lighting is an excellent indication that the DLC's incoming power has been wired successfully and voltage is present. Characters may or may not appear on the display. This is normal and will be covered in the next section.



WITHOUT PRIOR OPERATING KNOWLEDGE, IT IS IMPOSSIBLE TO TELL IF THE PULSAR MOTOR WILL RUN WHEN POWER IS APPLIED TO THE DLC. YOU ARE RESPONSIBLE FOR TAKING THE NECESSARY STEPS TO ENSURE THAT ALL ASPECTS OF SAFETY HAVE BEEN CONSIDERED (E.G., ELECTRICAL, HYDRAULIC, ETC.). IF IN DOUBT, DISCONNECT THE MOTOR FROM J3 PRIOR TO APPLYING POWER.



THE DLC DETECTS ANY ADJUSTMENTS MADE TO MANUAL ADJUSTMENT KNOB WHILE ITS POWER IS OFF. IF IT DETECTS THAT THE KNOB POSITION HAS BEEN CHANGED, IT WILL PERFORM A ZERO CALIBRATION WHEN THE MOTOR IS STARTED. THIS ACTION IS NORMAL.

Turn on power at the main. If the DLC's incoming power is connected correctly, the back-lighting on the DLC's display will illuminate (depending on lighting conditions, it may be necessary to shade the display to confirm illumination). If the display is not illuminated, first check the line

voltage with a volt meter. If the voltage is not correct, return to **Section 5: Installation: High-Voltage Connections**. Otherwise, proceed with the next step.

6.1.4 Confirm Display and Keypad Functionality



THE EXAMPLE DISPLAY MESSAGES ARE SHOWN IN ENGLISH FOR DEMONSTRATION PURPOSES. IF AN ALTERNATE LANGUAGE HAS BEEN SET, THE TEXT IS DISPLAYED AS A TRANSLATION OF THE ENGLISH VERSION.

Now that you have confirmed that the DLC is receiving power, it is necessary to confirm that the display and keypad are functioning properly. On normal power-up, the {SELF-TEST} display appears for approximately 5 seconds. After that time, the display will change the message to one of the following:

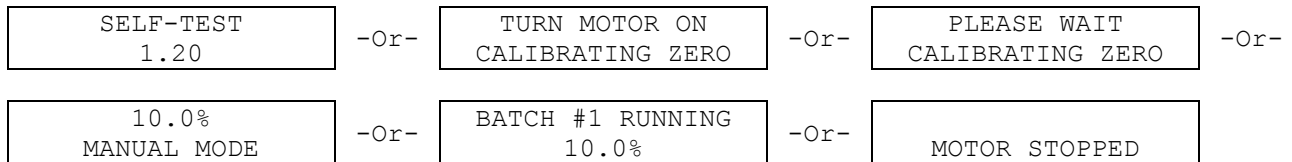

At this time, the actual message is not important; the characters should be visible and form a reasonable message.

If the display is blank (no-characters) then the display contrast must be adjusted. This is accomplished by pressing and holding [MENU] while simultaneously pressing [UP]. This will darken the display.

Be patient! You may have to hold both keys down for as long as 30 seconds before the characters will become visible. If the display is too dark, press [MENU] and [DOWN] simultaneously to decrease (lighten) the contrast. Once the contrast is properly adjusted, check the message displayed. If it does not look similar to one of those shown above, proceed directly to the next section to perform a Factory Re-initialization on your DLC.

The keypad can be tested by depressing each key separately. Most, but not all keys will cause the text on the display to change. Do not be alarmed if a single key does not invoke a change to the display. This is normal. Different keys become active/inactive depending on the current operating mode.

There are a number of functions that the DLC performs (e.g., zero calibration) where the keypad has no effect. If the stroke adjustment knob is not moving, at least one key on the key pad should cause the text on the display to change. Go to **Section 6.1.6**. If this is not the case, refer to **Section 11, Troubleshooting**.

6.1.5 Performing a Factory Re-initialization



WHEN RE-INITIALIZING YOUR DLC, ALL OF THE SYSTEM SETTINGS WILL BE OVERWRITTEN BY THE ORIGINAL FACTORY DEFAULT SETTINGS. THE CONTROLLER MUST BE RE-CONFIGURED TO YOUR SPECIFICATIONS (E.G., RE-CALIBRATED).

If your DLC appears to be functioning properly – the display is similar to one of those shown on the previous page – skip to **Section 6.1.6**.



A FACTORY RE-INITIALIZATION RESTORES ALL FACTORY DEFAULTS TO THE DLC'S MEMORY, AND TYPICALLY IS NOT REQUIRED.

A Factory Re-initialization should be performed only if there is reason to believe that the internal DLC memory has become corrupted. A number of factors could cause this including: long-term storage, disregard of electrostatic precautions during installation (refer to **Section 2: Safety**), improper wiring, voltage surges, etc. The condition usually manifests itself with inconsistent or erratic operation – often associated with characters on the display. Depending on the state of your DLC, use one of the following procedures:



STARTUP FACTORY RE-INITIALIZATION

Use this procedure when you cannot read the display, or if the DLC does not seem to be responding to your key presses:

1. Cycle power to the unit (turn it OFF then ON).
2. Within the first 5 seconds of power on, depress and hold the [UNITS], [MODE], and [ENTER] keys simultaneously for approximately 1 second.
3. The display will continue to display the version number while the DLC's memory is restored. The display will then show {TURN MOTOR ON / CALIBRATING ZERO}. Return to **Section 6.1.4: Confirm the Display and Keypad Functionality**.



MENU FACTORY RE-INITIALIZATION

Use this procedure if the display and key pad appear to be functioning properly, but you suspect other problems with data corruption, erratic operation, etc. Factory Re-initialization can be found in the Configure Menu. Perform the following steps:

1. Apply power to the unit. Wait for the {SELF-TEST} display to disappear. The unit should display a standard power on screen.
2. Press [MENU]. The display will show the first menu item {DIAGNOSTICS}.
3. Press [DOWN]. The {FACTORY DEFAULTS} menu item should be displayed. If not, continue pressing [DOWN] until it does.
4. Press [ENTER]. The prompt {FACTORY RESET? / NO} is displayed.
5. Press [UP]. The prompt will read {FACTORY RESET? / YES}.
6. Press [ENTER] to accept the {YES} prompt. The prompt {ARE YOU SURE? / NO} is displayed.
7. Press [UP]. The prompt will read {ARE YOU SURE? / YES}.
8. Press [ENTER] to accept the {YES} prompt.
9. The display will read {PLEASE WAIT} for approximately 5 seconds while the DLC's memory is restored. The display should then display {TURN MOTOR ON / TESTING ENCODER}. Return to **Section 6.1.4: Confirm Display and Keypad Functionality**.

6.1.6 Test Pump Motor



THE LEVEL INPUT, PULSALARM AND SIGNAL LOSS INPUTS CAN BE CONFIGURED TO SHUT THE MOTOR DOWN IF THEY ARE ENABLED. IF THIS IS THE CASE, A MESSAGE IS DISPLAYED ON THE SCREEN INDICATING THE FAILURE. YOU CANNOT RE-START THE MOTOR UNTIL THESE INPUTS HAVE BEEN CORRECTED OR THE {MOTOR OFF} OPTION HAS BEEN DISABLED. REFER TO SECTION 7: GENERAL OPERATION FOR FURTHER INFORMATION ON CONFIGURING THESE OPTIONS.

To test the PULSAR motor connection, press [MOTOR]. If the motor is running it should stop and the display should read {MOTOR STOPPED} or {TURN MOTOR ON / CALIBRATING ZERO} or {TURN MOTOR ON / TESTING ENCODER} as shown below.

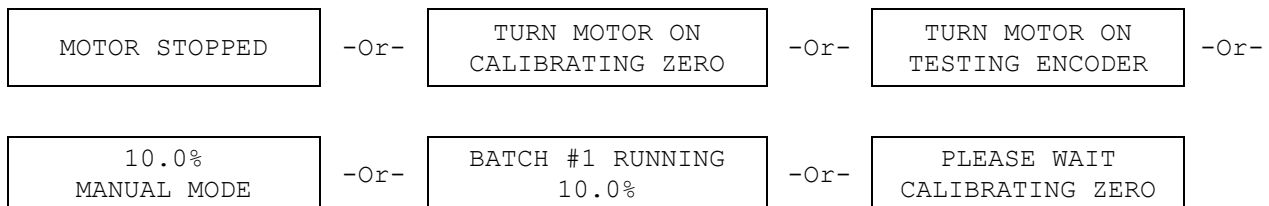

If the display appears as shown above, but the PULSAR motor does not start, return to **Section 5: Installation: High-Voltage Connections** and check your wiring. If the wiring is correct, refer to **Section 11: Troubleshooting**.



CHECK FOR TURNING MOTOR FAN BLADES INSIDE THE GUARD TO OBSERVE MOTOR OPERATION. ALSO, CHECK FOR FLUID DISCHARGE.

6.1.7 Set Time and Date

The clock on your DLC has been activated at the factory, but you should set it to the local time and date of the installation site.

Time and Date are set in the Configuration Menu. Below is an example that accepts some software default values:



SET TIME AND DATE PROCEDURE

1. From the Current Operating Mode Display, press [MENU]. The {-MENU- / DIAGNOSTICS-0} screen is displayed (refer to illustrations below).
2. Press [UP] one time. The {-MENU- / SET TIME AND DATE} screen is displayed.
3. Press [ENTER]. The date and time screen is displayed.
4. Press [ENTER] to accept the 24 Hour time setting.
5. Press [UP] or [DOWN] to adjust the hour value displayed to the local time. Press [ENTER].
6. Press [UP] or [DOWN] to adjust the 10 minute value displayed to the local time. Press [ENTER].
7. Press [UP] or [DOWN] to adjust the minute value displayed to the local time. Press [ENTER] twice (to accept the default MM/DD/YY format setting).
8. Press [UP] or [DOWN] to adjust the month value displayed to the current month. Press [ENTER].
9. Press [UP] or [DOWN] to adjust the day value displayed to the current day. Press [ENTER].
10. Press [UP] or [DOWN] to adjust the year value displayed to the current year. Press [ENTER] twice (accepting the default Daylight Savings NO setting).

The time and date information has now been set.

-MENU- DIAGNOSTICS - 0	Press [UP]	-MENU- SET TIME AND DATE	Press [ENTER]	24 HR 21:07	MM/DD/YY 1/22/01
---------------------------	---------------	-----------------------------	------------------	----------------	---------------------

Refer to **Section 7: General Operation, Set Time and Date** for more detailed instructions on how to set the Time and Date information.

6.1.8 Flow Calibration (1-point)

Your DLC is factory calibrated at rated flow and pressure (1-point). Nevertheless, you should always perform a calibration with the PULSAR DLC installed in your system. The only item required to calibrate your DLC is a means to measure the output of the pump (i.e., calibration column, graduated cylinder, etc.).



1-POINT CALIBRATION PROCEDURE

1. Press [MOTOR] to start the motor (if the motor is not currently running).
2. Press [UNITS] repeatedly until a unit that is consistent with your flow measurement device (i.e., calibration column) appears. For example, if your column reads in Liters then set the display to LPM or LPH. Liters will be used in this example.
3. Press [CAL]. The {CALIBRATE / PUMP FLOW} screen is displayed.
4. Press [ENTER]. The {LAST FLOW CAL / 11:32 1/22/01} screen is displayed.
5. Press [ENTER]. The {FLOW CALIBRATION / 1-POINT} screen is displayed.
6. Press [ENTER]. The {CALIBRATE ZERO? / YES} screen is displayed.



IF YOU ARE CONFIDENT WITH THE QUALITY OF YOUR ZERO CALIBRATION, PRESS [UP] AND THE {CALIBRATE ZERO? / NO} SCREEN IS DISPLAYED. PRESS [ENTER] AND CONTINUE WITH STEP 10.

7. Press [ENTER]. The {TURN MOTOR ON / TESTING ENCODER} screen is displayed, or if the pump motor was ON when you started the calibration process, the {PLEASE WAIT / TESTING ENCODER} screen is displayed.
8. Turn the pump motor on if necessary and the encoder performs its self-test. When the self-test is completed, the {PLEASE WAIT / CALIBRATING ZERO} screen is displayed. The DLC will adjust the stroke to the 0% position.
9. The {PLEASE WAIT / XX% 100%} screen is displayed. The DLC will adjust the stroke to the 100% position. The PULSAR motor will shut off.

PLEASE WAIT XX% 100%

10. The {ENTER TO START/ 100% 2.641718 G} screen is displayed. The value '2.641718' represents the amount of fluid discharged over 60 seconds the last time a calibration was performed at the 100% stroke setting. Record the fluid base reading from your calibration column.
11. Press [ENTER]. The PULSAR motor will start to run. A timer is displayed counting down from 60 seconds. After 60 seconds the motor will stop automatically.

TIMER: XX SEC 2.641718 G

12. The {ENTER VALUE 100% / 2.641718 G} screen is displayed. Calculate the measured volume displaced from the calibration column and enter the new value one position at a time using [UP] and [DOWN] to change an individual position. Press [ENTER] to move the cursor to the next position.
13. Pressing [ENTER] on the last position will cause the {CONFIRM CHANGE? / YES} screen to be displayed. Press [ENTER] to accept. Your 1-point calibration is now complete.

Refer to **Section 7: General Operation, Calibration, Pump Flow** for more detailed instructions on how to perform DLC calibration.

6.1.9 Analog Input Calibration

If you are not using the 0-20mA input to the DLC for control, skip this section. To calibrate the Input Current you must first correctly wire an external signal source. Refer to **Section 5: Installation, Low-voltage Input Connections, Analog Input**. To perform a calibration, the signal generating device (e.g., PLC) must be powered up and capable of altering its output from minimum to maximum signal.

6.1.9.1 Analog Input Calibration



THE FOLLOWING IS A MINIMAL PROCEDURE FOR CALIBRATING THE ANALOG INPUT.

1. Press [CAL]. The {CALIBRATE / PUMP FLOW} screen is displayed.
2. Press [UP]. The {CALIBRATE / ANALOG IN} screen is displayed.
3. Press [ENTER]. The {0% = 4.0mA / 100% = 20.0mA} screen is displayed. These values represent the previous calibration.
4. Press [ENTER]. The {INPUT ANALOG MIN / 0% = XXmA} screen is displayed. Adjust your PLC to output a minimum signal (i.e., 4.0mA). The DLC display will update as the incoming signal changes.
5. When the displayed value stabilizes, press [ENTER] to accept it. The {INPUT ANALOG MAX

/ 100% = XXmA} screen is displayed. Adjust your PLC to output a maximum signal (i.e., 20.0mA). Again, the DLC display will update with the changing signal.

6. When the displayed value stabilizes, press [ENTER] to accept it. The {INPUT RATIO / 100% = XX.XmA} screen is displayed.
7. Press [ENTER] to accept the 100% Ratio setting. The {CONFIRM CHANGE? / YES} screen is displayed.
8. Press [ENTER]. Analog input calibration is now complete.

Refer to **Section 7: General Operation, Analog Input Signal Calibration** for more detailed instructions on how to perform Analog Input calibration.

Wrapping Up

Your PULSAR DLC is now commissioned for use. Refer to **Section 7: General Operation** for specific instructions on how to access your DLC's advanced features. Please don't be intimidated by your DLC, take time to explore and experiment with its features. Remember, you cannot configure the software in a way that would damage the DLC. Typically, whenever you are about to set a critical value (e.g., Calibrate Flow), you are always prompted to confirm your change before it takes effect. If you are ever dissatisfied with the configuration of your DLC, you can always return to the Factory Defaults by repeating **Section 6.1.5**.

7 General Operation

This section covers the General Operation of the DLC as it relates to software. It includes detailed instructions and example screens. The default values of the DLC have been set at the factory. You can over-ride these settings to tune the DLC to your particular needs.

7.1 General Operation Instructions

7.1.1 Pump Flow Calibration

Pulsafeeder recommends performing at minimum a Two-Point flow calibration on every PULSAR DLC installed. Maintenance re-calibration should be performed periodically – at least every three to four months – to account for component wear. Re-calibration of the pump is also recommended whenever wet-end components are replaced.



THE DLC DOES NOT AUTOMATICALLY COMPENSATE FOR CHANGING SYSTEM CONDITIONS (E.G., DISCHARGE PRESSURE, FLUID VISCOSITY, ETC.). YOU SHOULD RE-CALIBRATE WHENEVER THE APPLICATION CONDITIONS CHANGE.



THE CALIBRATION PROCESS AFFECTS THE STROKE ADJUSTMENT MECHANISM ONLY.



MULTI-POINT CALIBRATION PROCEDURE

1. Press [CAL] to enter the Calibration Menu. Press [ENTER] to go to the calibrate pump flow sub-menu:

CALIBRATE PUMP FLOW	Press [ENTER]
------------------------	------------------

2. The DLC displays the last time the pump was calibrated. Press [ENTER] to continue with pump flow calibration.

LAST FLOW CAL 3:25 1/22/01	Press [ENTER]
-------------------------------	------------------

- The display shows {FLOW CALIBRATION / 1 POINT}. The '1 POINT' text will be flashing.

FLOW CALIBRATION 1 POINT	Press [UP]
-----------------------------	---------------

Press [UP] to change flow calibration to 2 points, 3 points, 4 points or 5 points. The calibration points correspond to the following stroke length values: 100, 75, 50, 25, and 10.



A 1-POINT CALIBRATION SHOULD BE AVOIDED IN APPLICATIONS WHERE THE DISPLAYED FLOW RATE IS CRITICAL. FOR DISCHARGE PRESSURES LESS THAN 500 PSI (34.5 BAR), A MINIMUM 2-POINT CALIBRATION IS RECOMMENDED. FOR DISCHARGE PRESSURES ABOVE 500PSI (34.5 BAR) A MINIMUM 3-POINT CALIBRATION IS RECOMMENDED.

These percentage values correspond to the API standards. If you continue to press [UP] you will also see the following options: {CHANGE CONSTANTS} and {TUNE}. These options are for use after a multi-point calibration has been performed. For a standard multi-point calibration, set the number of calibration points to use and press [ENTER] to continue.



YOU CAN "SKIP" A CALIBRATION POINT BY ENTERING A FLOW VALUE OF 0.0000. "SKIPPING" A POINT MEANS THAT IT WILL BE OMITTED FROM THE MATHEMATICAL REGRESSION TO ESTABLISH THE FLOW CURVE. VALUES WHICH ARE LESS THAN 10% OF THE PUMPS' RATED OUTPUT FLOW SHOULD BE SKIPPED.

- Press [ENTER]. The {CALIBRATE ZERO? / YES} screen is displayed.

CALIBRATE ZERO? YES	Press [ENTER]
------------------------	------------------



IF YOU ARE CONFIDENT WITH THE QUALITY OF YOUR ZERO CALIBRATION, PRESS [UP] AND THE {CALIBRATE ZERO? / NO} SCREEN IS DISPLAYED. PRESS [ENTER] AND CONTINUE WITH STEP 8.

- Press [ENTER]. The {TURN MOTOR ON / TESTING ENCODER} screen is displayed, or if the pump motor was ON when you started the calibration process, the {PLEASE WAIT / TESTING ENCODER} screen is displayed.

TURN MOTOR ON TESTING ENCODER	- Or -	PLEASE WAIT TESTING ENCODER
----------------------------------	--------	--------------------------------

- Turn the pump motor on if necessary and the encoder performs its self-test. When the self-test is completed, the {PLEASE WAIT / CALIBRATING ZERO} screen is displayed.

PLEASE WAIT CALIBRATING ZERO

- The DLC will now perform a ZERO CALIBRATION. First, it will turn on the pumps motor. Then it will test the encoder's position by increasing the stroke adjustment mechanism 2%. Then the DLC will adjust in the opposite direction until it reaches the mechanical zero stop (0% stroke setting). This ensures that the positioning mechanism is working properly and calibrations will be accurate. The screen will display one of four messages:

PLEASE WAIT CALIBRATING ZERO	- Or -	TURN MOTOR ON TESTING ENCODER
---------------------------------	--------	----------------------------------

If the {TURN MOTOR ON...} screen is displayed, start the PULSAR motor by pressing [MOTOR]. The DLC will adjust to the 100% position. If you get the {ENCODER ERROR...} screen, refer to **Section 11: Troubleshooting Guide**.

8. The following screen is displayed.

PLEASE WAIT
XXX.X% 100%

If you get the {PRESS ENTER / TO START MOTOR} screen, start the PULSAR motor by pressing [ENTER] or [MOTOR].

The XXX.X% represents the current stroke length adjustment setting and 100% is the stroke length destination.

9. Once the destination setting has been reached, the PULSAR motor will shut down and the display will show:

ENTER TO START
2.641718 G



THE DISPLAY IS SHOWING THE AMOUNT OF FLUID DISCHARGED FROM THE PUMP THE LAST TIME THIS OPERATION WAS PERFORMED (E.G., 2.641718 GALLONS). THIS FLOW RATE IS BASED ON 60 SECONDS OF PUMP OPERATION. FILL THE CALIBRATION COLUMN IN THE SYSTEM TO THE PROPER LEVEL TO AVOID RUNNING THE PUMP DRY DURING CALIBRATION.

10. When you are ready, press [ENTER], which will start the pump motor for a period of 60 seconds. The screen will show a 60 second timer and display its count down toward 0 seconds. During this time, the pump is operating at the designated stroke length setting.

TIMER: 60 SEC
2.641718 G



IF YOU ALREADY KNOW THE DISPLACED VOLUME, YOU CAN BYPASS THE 60 SECOND TIMER BY PRESSING [UP] AND [DOWN] SIMULTANEOUSLY.

11. At the end of 60 seconds, the pump motor will automatically turn off. The display will automatically change to prompt you to enter the new measured flow rate.

ENTER VALUE 100%
2.641718 G

Read the new measured flow from the calibration column. Enter the new value one position at a time using [UP] or [DOWN]. Press [ENTER] to accept each digit setting and move the cursor to the next position. Continue to use the arrow keys and press [ENTER] on the last position to accept your setting.



IF YOU MAKE A MISTAKE ENTERING THE MEASURED FLOW RATE AND REALIZE IT BEFORE PRESSING [ENTER] ON THE LAST POSITION, PRESS [UP] AND [DOWN] SIMULTANEOUSLY AND THE CURSOR IS RETURNED TO THE FIRST DIGIT.



IF YOU WOULD LIKE TO "SKIP" A CALIBRATION POINT, ENTER A VALUE OF 0. ANY MEASURED VOLUME WHICH TRANSLATES TO LESS THAN 10% OF THE MAXIMUM RATED FLOW OF THE PUMP WILL BE DISREGARDED FROM THE CALIBRATION ROUTINE. TO DO THIS, ENTER A VALUE OF 0.0000.

12. If a 2 through 5 point calibration was selected, the DLC will automatically proceed to the next stroke length setting and repeat steps 8, 9, 10, and 11 as described above. After the DLC has completed the above referenced process for all stroke length settings, it prompts you to accept the data collected in the above referenced steps:

CONFIRM CHANGE?
YES

13. Press [ENTER] to accept the calibration. The DLC will display a {PLEASE WAIT} message while it performs the Least Squares curve fit to the data points and calculates the new flow curve. Any point entered with a value of 0.0000 will be ignored by the curve fitting routine. If you do not want to accept the new calibration, press [UP] to scroll to {NO} and press [ENTER]. The display is then returned to its original operating mode.



CHANGE CONSTANTS PROCEDURE

1. Navigate to the Change Constants menu by pressing [CAL]. The {CALIBRATE / PUMP FLOW} menu is displayed. Press [ENTER] twice. The {FLOW CALIBRATION / 1 POINT} menu is displayed.
2. Press [UP] until {FLOW CALIBRATION / CHANGE CONSTANTS} is displayed.

FLOW CALIBRATION CHANGE CONSTANTS

This option is used to set the slope and y-intercept in the equation that describes the linear calibration curve: $y = ax + b$. Where 'a' is the slope and 'b' is the y-intercept. The input to this equation (i.e., x) is given in flow (GPM). The output (i.e., y) represents stroke position in percent (%). The units for the constants are given on screen. Values can be calculated from two or more flow readings and associated stroke settings.

3. Press [ENTER] and the display prompts you to enter the slope value:

SLOPE	%/GPM
0.3785415569416	

You edit the calculated slope value in the displayed units (%/GPM in the example above) value one position at a time. Press [UP] or [DOWN] to set the digit. Press [ENTER] to move to the next digit.

It is possible for the CHANGE CONSTANTS display of numbers to be larger than the 16 character screen. If you have a number that overflows the screen in one direction or the other, a greater than (>) or less than (<) symbol is displayed to indicate this (e.g., <0.3785415569416>). Pressing [ENTER] as you edit the number string, moves the cursor one position to the right. Pressing [ENTER] on the last displayed number will shift the display one position to the left. This pattern will continue until the last digit in the string is reached. Press [ENTER] on the last digit to accept your change.

4. The display prompts you to enter the y-intercept.

Y-INTERCEPT
0.00%

Use [UP] and [DOWN] to enter the calculated y-intercept value. The value can be positive or negative (typically the value will be positive). Press [ENTER]. The {CONFIRM CHANGE? / YES} menu is displayed. Press [ENTER] to accept your changes. The DLC will convert the constants to the other display units automatically.

The display is then returned to its original operating mode.



CALIBRATION / TUNE FLOW PROCEDURE

1. In this sub-menu the flow curve can be shifted to 'tune' the flow to one given point. The reason you might perform this procedure is the process you are currently running is too critical to be shut down to complete a full calibration. The Tune Flow procedure is a quick fix. Before entering the TUNE sub- menu, you should measure the actual flow rate at a specific stroke setting. For example, the DLC is currently set at 60.0% stroke and it displays a calibrated flow rate of 6.0 GPH. An actual flow measurement is taken and found to be 5.775 GPH. Leaving the stroke setting at 60%, tune the flow rate to 5.775 GPH.



SINCE THE {TUNE FLOW} SCREEN DISPLAYS FLOW PER MINUTE, THE FLOW PER HOUR WILL HAVE TO BE CONVERTED. FOR EXAMPLE:

$$6.0 \text{ GPH} / 60 \text{ minutes per hour} = 0.1 \text{ GPM}$$

2. Navigate to the Change Constants menu by pressing [CAL]. The {CALIBRATE / PUMP FLOW} menu is displayed. Press [ENTER] twice. The {FLOW CALIBRATION / 1 POINT} menu is displayed. Press [UP] until {CALIBRATION / TUNE} is displayed. Press [ENTER] to accept and continue with the {CALIBRATION / TUNE} menu. The following screen is displayed:

TUNE FLOW	60.0%
	0.1000 G

Using [UP] or [DOWN] enter the volume displaced for 1 minute of pump flow at the current stroke length. The percentage value displayed represents the net pump output. Press [ENTER]. The pump will now display the 5.775 GPH value at the 60.0% stroke setting. Internally, the DLC has retained the slope calculated at the last calibration and has off-set the flow curve to satisfy the current reading requirement.

7.1.2 Analog Input Signal Calibration

The DLC will accept analog input signals of 0-20mA, 4-20mA, 1-5mA, or 1-5 volts. The analog input signal should be calibrated to the system. To perform a calibration, the signal generating device (e.g., PLC) must be powered up, wired to the DLC and capable of altering its output from minimum to maximum signal. **Refer to Section 5: Installation, Low-Voltage Input.**



YOU ARE CALIBRATING THE ANALOG INPUT SIGNAL TO THE PERCENTAGE OF CALIBRATED FLOW. THE 0% AND 100% VALUES DISPLAYED IN THIS SECTION REFER TO A PERCENTAGE OF FLOW NOT STROKE POSITION. IN A HIGH PRESSURE APPLICATION, IT IS POSSIBLE THAT THE PULSAR WILL NOT DISCHARGE FLUID BELOW 10% STROKE LENGTH. THUS IT HAS 0% FLOW AT 10% STROKE. IF YOU CALIBRATE 0% = 4.0MA, AND THEN INPUT A 4.0MA SIGNAL THE DLC WILL ADJUST THE STROKE LENGTH TO 10%.

7.1.2.1 Analog Input Calibration

The following is a minimal procedure for calibrating Analog Input #1. This will control the DLC's Stroke Length (Calibrated). For more information about the Analog Input signal, refer to **Section 7.2.15: Analog Mode.**

ANALOG INPUT #1 CALIBRATION PROCEDURE

1. Press [CAL]. The {CALIBRATE / PUMP FLOW} screen is displayed.

CALIBRATE
PUMP FLOW

2. Press [UP] to scroll to the {CALIBRATE / ANALOG IN}.

CALIBRATE
ANALOG IN

3. Press [ENTER]. The display shows the previous 0% and 100% flow analog signal calibration values:

0%	=	4.0 MA
100%	=	19.8 MA



IF YOU WOULD LIKE TO SKIP THE CALIBRATION AND CHANGE ONLY THE SIGNAL RATIO, PRESS BOTH [UP] AND [DOWN] SIMULTANEOUSLY. SKIP TO STEP 6. PRESSING BOTH [UP] AND [DOWN] CAN ALSO SKIP EITHER THE MIN. OR THE MAX CALIBRATION.

Press [ENTER] to continue with Analog Input Calibration.

- The display prompts you to input the minimum analog signal value, 0% flow.

```
INPUT STROKE MIN
0% = XX.X MA
```

Send the low analog signal to the DLC (i.e., 0mA, 1mA, 4mA or 1 volt input to the J4 **Current 1** terminals) from the signal generating device (e.g., PLC). Refer to **Section 5: Installation, Low-Voltage Input** and **Figure 5** for the wiring instructions. It is highly recommended that you use the actual signal the DLC will be receiving during operation. The DLC will display its interpretation of the received signal. Do not be alarmed if the signal does not match the instrument.

For example, your instrument is generating 4.0mA but the DLC display reads 3.6mA. The DLC also accepts voltage inputs (0-5VDC), but displays only mA. It is only important that the DLC detects the full range of the instruments output. The DLC will store this value as the 0% analog signal value. As the analog signal varies, the DLC will display the fluctuating values. Wait approximately 10 seconds until the value displayed stabilizes and press [ENTER] to accept it as the 0% flow analog signal value.

- The display prompts you to input the maximum analog signal value, 100% flow. Send the maximum analog signal to the DLC (i.e., 10mA, 20mA or 5 volts).

```
INPUT STROKE MAX
100% = XX.X MA
```

As the signal varies, the DLC will display the fluctuating values. Wait approximately 10 seconds until the value stabilizes and press [ENTER]. The DLC stores this value as the 100% flow analog signal value.

If the range between the minimum and maximum analog signal values is less than or equal to 2mA, the DLC will display the following:

```
RANGE TOO SMALL
RE-ENTER
```

Press [ENTER] to return to step 4 to input the analog signal values again.

- You are now ready to set the Signal Ratio. This option allows you to scale the Analog signal input to the pump output. Use this option only if you want to limit the range of operation of the pump (e.g., you want to limit the pump's output from 0 to 50% flow over the 4-20mA range). The display reads as follows:

To use the ratio option, Press [UP] or [DOWN] to set the ratio value. Press [ENTER] to accept the setting.

```
STROKE RATIO
50% = 19.8 MA
```



IF YOU DO NOT WANT TO USE THE INPUT RATIO OPTION, ENTER A VALUE OF 100%

- The DLC prompts you to accept the analog signal calibration programmed in the above referenced steps.

```
CONFIRM CHANGE?
YES
```

Press [ENTER] to accept. If you do not want to accept the new analog signal calibration, press [UP] to scroll to {NO} and press [ENTER].

The display will then return to its original operating mode.

7.1.3 Reverse Acting Analog Input Signal Calibration

To set up a reverse acting application, follow the above Analog Input Calibration procedure with the following changes to step 6 and step 7.

1. In step 4, when the display requests the minimum analog signal value (0% flow), you should send the DLC the high analog signal value (i.e., 10mA, 20mA or 5 volts).

INPUT ANALOG MIN 0% = XX.X MA	Send high (20 mA) signal
----------------------------------	-----------------------------

The DLC will store this as the 0% analog input signal value. As the analog signal varies, the DLC will display the fluctuating values. Wait approximately 10 seconds for the signal to stabilize. Press [ENTER] to accept this as the 0% analog signal value.

2. In step 5, when the display requests the maximum analog signal value (100%), you send the DLC the low analog signal value (i.e., 0mA, 1mA, 4mA or 1 volt).

INPUT ANALOG MAX 100% = XX.X MA	Send low (4 mA) signal
------------------------------------	---------------------------

The DLC will store this as the 100% analog input signal value. As the signal varies, the DLC will display the fluctuating values. Wait approximately 10 seconds for the signal to stabilize. Press [ENTER] to accept this signal as the 100% analog signal value.

You can confirm the reverse acting input signal calibration by re-entering the Analog Input Calibration menu. The first screen summarizes your calibration.

0% = 20.0 MA 100% = 4.0 MA

3. Press [CAL] again to cancel the calibration at this point.

7.1.4 Analog Output Signal Calibration

The DLC will generate an analog output signal proportional to the calibrated output of the pump. The signal can be calibrated to a standard range of 0-20mA, 4-20mA, 1-5mA, or 1-5 volts. It should be calibrated to the attached system.

For more information on configuring the Analog Output Signal refer to **Section 7.2.6: Analog Output Setup**.



THE DISPLAY VALUE (E.G. 4.0mA) IS FOR REFERENCE ONLY. DO NOT BE CONCERNED IF THIS VALUE DOES NOT EXACTLY MATCH THE MEASURED ANALOG OUTPUT SIGNAL READ BY ATTACHED EQUIPMENT. AS YOU INCREASE THIS NUMBER THE OUTPUT WILL INCREASE, AS YOU DECREASE THIS NUMBER OUTPUT WILL DECREASE. IT IS IMPORTANT THAT THE MEASURED OUTPUT MATCHES YOUR REQUIREMENT.

THE ANALOG OUTPUT REFLECTS THE CALIBRATED OUTPUT (E.G., FLOW) NOT THE MECHANICAL OUTPUT (E.G., STROKE POSITION).

IF THE PUMP MOTOR IS OFF, THE OUTPUT WILL REPRESENT THE MINIMUM VALUE (E.G., 0%).

1. Press [CAL] to enter the {CALIBRATE} sub-menu. Press [UP] twice to scroll to the {ANALOG OUTPUT} selection:
2. Press [ENTER]. The screen that allows you to set the output at 0% is displayed.

OUTPUT AT 0%
4.0 ma

Using [UP] or [DOWN], set the value for the desired output. Note the value that you set is for reference only. If you need a true 4.0mA's at the remote equipment, you should read the actual value from the remote equipment and set the value here at whatever is required by that equipment. For example, say a remote PLC needs exactly 4.0mA's at 0% stroke. The PLC currently reads its input as 3.8mA and the DLC display shows its output as 4.0mA. Increase the DLC output (e.g., 4.2mA) until the PLC reads 4.0mA correctly.

3. Once you have set the 0% value press [ENTER] to accept it. The screen that allows you to set the output at 100% is displayed.

OUTPUT AT 100%
20.0 MA

As described in step 2, set the output using [UP] or [DOWN]. When you are satisfied with your settings press [ENTER] to accept it.

4. The DLC will prompt you to accept the analog output calibrated values.

CONFIRM CHANGE?
YES

Press [ENTER] to accept the calibration. If you do not want to accept, press [UP] to display {NO} and then press [ENTER].

The display will return to the last operating mode.



YOU CAN SET THE ANALOG OUTPUT TO REVERSE ACTING BY SIMPLY SETTING THE OUTPUT AT 0% TO BE 20.0MA AND THE OUTPUT AT 100% TO BE 4.0MA.

7.2 Menu

The default values of the DLC Controller have been factory set, but you may want to configure the DLC to meet your specific application.

The [MENU] key activates the Configuration Menu system. This consists of 23 different sub-menus as shown below. Press [UP] or [DOWN] to scroll through the sub-menus

-MENU- DIAGNOSTICS - 0	Press [UP]	-MENU- SET TIME & DATE	Press [UP]	-MENU- ANALOG SIG FAIL	Press [UP]
-MENU- MODBUS SIG. FAIL	Press [UP]	-MENU- LEAK DETECTION	Press [UP]	-MENU- LEVEL SWITCH	Press [UP]
-MENU- DIGITAL OUTPUT	Press [UP]	-MENU- MOTOR THERMOSTAT	Press [UP]	-MENU- OVER TEMPERATURE	Press [UP]
-MENU- POWER FAILURE	Press [UP]	-MENU- ALARM RELAY	Press [UP]	-MENU- ANALOG MODE	Press [UP]
-MENU- MODBUS MODE	Press [UP]	-MENU- SECURITY	Press [UP]	-MENU- NUMBER FORMAT	Press [UP]
-MENU- CONTRAST ADJUST	Press [UP]	-MENU- SERIAL COMM	Press [UP]	-MENU- SERIAL DIAG.	Press [UP]
-MENU- LANGUAGE	Press [UP]	-MENU- FACTORY DEFAULTS	Press [UP]		

Pressing the [UP] key takes you back to the {-MENU- DIAGNOSTICS-0} screen.



NOTE

AS YOU GO THROUGH THIS SECTION OF THE MANUAL, THE SCREENS ARE DISPLAYED AS DEFINED IN THE FACTORY DEFAULT SETTINGS. IF ANY OF THE SETTINGS ARE CHANGED, (E.G., DURING INITIAL SETUP OR MODIFYING OPERATING PARAMETERS) THE AVAILABILITY OF SCREENS DISPLAYED WITHIN A SUB-MENU MAY CHANGE.

7.2.1 Alarm and Error Messages

When an error occurs, the DLC flashes Alarm and Error messages alternately with the standard display. If the error is catastrophic (e.g., Tachometer Failure), the catastrophic error message will remain displayed until the problem is repaired.

The following table gives an example of these messages and when you can expect them to be displayed.

MESSAGE	DISPLAYED WHEN
ANALOG SIG FAIL	The Analog signal has fallen below its calibrated range or fallen rapidly (indicating an open circuit).
LEAK DETECTION	The PULSAlarm leak-detection diaphragm has failed.*
LEVEL SWITCH	The Drum Level switch has been activated.*
POWER FAILURE	The input power to the DLC was interrupted while the pump motor was running.*
OVER TEMPERATURE	The internal temperature of the DLC has exceeded its operating limit.*
ALARM RELAY	If configured, this message is displayed when the alarm relay activates.
DUTY CYCLE	When displayed, indicates that the stroke adjustment motor has run continuously for more than 20 minutes and is now in a cool down phase.
MOTOR THERMOSTAT	The temperature of the DLC Pump Motor has reached its operating limit.*
REMOTE ON/OFF	If configured, displays when the remote On/Off switch is in the Off position.
TERMINATED / PRESS ANY KEY	The Manual Control Knob moved during calibration.
POSITION ERROR	Motion of the stroke adjustment mechanism has not been detected when expected for a fairly long period of time.
MODBUS SIG FAIL	The digital command was not received within the timeout limit.
OVER VOLTAGE	The incoming power exceeds the specified range.
UNDER VOLTAGE	The incoming power is below the specified range.

*Refer to the **Diagnostics Section** (next section) for information on each of these messages.

7.2.2 Diagnostics

The DLC is supplied with a complete diagnostic menu. It will alert you if something has failed, the time and date of the failure, and allows you to clear the failure.



DIAGNOSTICS PROCEDURE

1. Press [MENU]. In a normal condition, the display reads {-MENU- / DIAGNOSTICS-0}.

-MENU- DIAGNOSTICS - 0



IF A DIAGNOSTIC FAILURE WAS DETECTED, THE {DIAGNOSTICS - #} WOULD APPEAR. THE '#' INDICATES THE NUMBER OF ITEMS THAT HAVE FAILED.

2. Press [ENTER] and the first diagnostic sub-menu is displayed. If the incoming power supply to the DLC was interrupted while the PULSAR motor was running, a failure will be detected and logged.

DIAG MENU 1/11 POWER IN: OK	- Or -	DIAG MENU 1/11 POWER IN: FAIL
--------------------------------	--------	----------------------------------

3. Press [UP] to scroll to the next sub-menu. If the analog signal fails, a failure will be detected and logged. An analog input failure is detected if one of the following conditions occurs. First, the signal falls below the calibrated range by 0.3mA (if the DLC is calibrated with a range of 4-20mA and the signal falls to 3.6mA then a failure will be logged). Second, if the analog signal falls below 0.3mA and is changing at a rate of 8.8 mA per second or more a failure will be logged. This second condition is primarily for the situation where the input is calibrated for 0 to 20mA's. Refer to **Section 7.2.4 Analog Signal Failure Setup** for further information.

DIAG MENU 2/11 ANALOG IN: OK	- Or -	DIAG MENU 2/11 ANALOG IN: FAIL
---------------------------------	--------	-----------------------------------

4. Press [UP] to scroll to the next sub-menu. If the MODBUS communications fails, a failure will be detected and logged. A MODBUS signal failure is logged when the DLC is in the MODBUS mode and the DLC has not received a valid digital command within the timeout limit.

DIAG MENU 3/11 MODBUS: OK	- Or -	DIAG MENU 3/11 MODBUS: FAIL
------------------------------	--------	--------------------------------

5. Press [UP] to scroll to the next sub-menu. If a PULSAlarm leak-detection diaphragm rupture is detected, the DLC will show a failure in this diagnostic sub-menu.

DIAG MENU 4/11 LEAK DET.: OK	- Or -	DIAG MENU 4/11 LEAK DET.: FAIL
---------------------------------	--------	-----------------------------------

6. Press [UP] to scroll to the next sub-menu. If the Level switch is configured as a {DRUM LEVEL} type and the switch is activated, the DLC will show a failure in this diagnostic sub-menu. If the Level Input is configured as {START/STOP}, a failure will not be logged.

DIAG MEU 5/11 LEVEL SW.: OK	- Or -	DIAG MENU 5/11 LEVEL SW.: FAIL
--------------------------------	--------	-----------------------------------

7. Press [UP] to scroll to the next sub-menu. The DLC is equipped with a pump motor thermostat to monitor pump motor temperatures. If the temperature has exceeded its operating limit, the DLC will show a warning in this diagnostic sub-menu.

DIAG MENU 6/11 MOTOR TEMP: OK	- Or -	DIAG MENU 6/11 MOTOR TEMP.: FAIL
----------------------------------	--------	-------------------------------------

8. Press [UP] to scroll to the next sub-menu. The DLC is equipped with a thermistor to monitor internal enclosure temperatures. If the temperature approaches its operating limit, (70°C or 158°F) the DLC will show a warning in this diagnostic sub-menu.

DIAG MENU 7/11 DRIVE TEMP: OK	- Or -	DIAG MENU 7/11 DRIVE TEMP: FAIL
----------------------------------	--------	------------------------------------

9. Press [UP] to scroll to the next sub-menu. The DLC is equipped with a clock that is backed by a 10- year lithium battery. If the battery fails, the DLC will show a failure in this diagnostic sub-menu. Consult factory.

DIAG MENU 8/11 BATTERY: OK	- Or -	DIAG MENU 8/11 BATTERY: FAIL
-------------------------------	--------	---------------------------------



IF THE BATTERY FAILS, MAINTAIN LINE POWER AND CONSULT THE FACTORY.

10. Press [UP] to scroll to the next sub-menu. If errors are detected with the RAM, EEPROM or internal synchronous stroke adjustment motor, the FAIL message will flash in this diagnostic sub-menu. The error is automatically cleared when the component is replaced and power is applied to the DLC.

DIAG MENU 9/11 CIRCUIT: OK	- Or -	DIAG MENU 9/11 CIRCUIT: FAIL
-------------------------------	--------	---------------------------------

If a failure occurs, you can access a sub-menu from the {DIAG MENU / CIRCUIT: FAIL} screen by pressing [ENTER]. The lower level menus show more descriptive circuit information.

Press [UP] to scroll between sub-menus.

The DLC tests its RAM at power-up. The results are shown as follows.

CIRCUIT FAILURE RAM: OK	- Or -	CIRCUIT FAILURE RAM: FAIL
----------------------------	--------	------------------------------

The DLC tests EEPROM whenever it writes information to long term memory

CIRCUIT FAILURE EEPROM: OK	- Or -	CIRCUIT FAILURE EEPROM: FAIL
-------------------------------	--------	---------------------------------

The {MOTOR: FAIL} message only indicates that the Stroke Adjustment motor was shutdown to keep it from overheating (i.e., it exceeded its Duty Cycle).

CIRCUIT FAILURE MOTOR: OK	- Or -	CIRCUIT FAILURE MOTOR: FAIL
------------------------------	--------	--------------------------------



CIRCUIT FAILURES CAN ONLY BE CLEARED BY CYCLING THE POWER TO THE DLC.

11. Press [UP] to scroll to the next sub-menu. The run time on the pump motor is displayed in this diagnostic sub-menu. To reset the run time, press [ENTER] and you are prompted to reset the total run time or continue counting the total operating hours.

DIAG MENU 10/11 RUN XXX HRS	Press [ENTER]	RESET RUN TIME? NO
--------------------------------	------------------	-----------------------

- Press [UP] to scroll to the next sub-menu. The total Stroke count of the pump is displayed here. To reset the Stroke count, press [ENTER] and you are prompted to {RESET COUNT?} or continue with the original count.

DIAG MENU 11/11 STROKES XXXX	Press [ENTER]	RESET COUNT? YES
---------------------------------	------------------	---------------------



IN STEPS 11 AND 12, IF YOU SELECT YES TO EITHER {RESET RUN TIME?} OR {RESET COUNT?}, THE {ARE YOU SURE?} PROMPT IS DISPLAYED. PRESS [UP] AND [ENTER] TO CONFIRM THE CHANGE.

- Press [ENTER] on any of the 'Fail' diagnostic screens (with the exception of BATTERY: FAIL and CIRCUIT FAIL) depicted above to display the time and date of the failure or more descriptive information.



ONLY THE FIRST OCCURRENCE OF AN ERROR WILL BE LOGGED. THE ERROR MUST BE CLEARED TO LOG FUTURE OCCURRENCES.

DIAG MENU 1/11 POWER IN: FAIL	Press [ENTER]	POWER FAILURE 13:27 1/22/01
----------------------------------	------------------	--------------------------------

- Press [ENTER] again, and you are prompted to clear the failure. Depending upon the type of failure diagnosed, you may want to take other steps before clearing the failure and restarting the pump. If so, press [ENTER] to keep the error date and time stamp. Otherwise, press [UP] to scroll to {YES} and press [ENTER]. The DLC will return to the first menu screen depicted in step 1.

POWER FAILURE CLEAR? NO

7.2.3 Set Time and Date

The clock/calendar is essential to the proper operation of the batch system and proper error time stamping. The clock should be set during installation. It can be configured to operate without any additional maintenance in most time zones.



SET TIME/DATE PROCEDURE

- Press [MENU], then [UP] to display the menu:

-MENU- SET TIME & DATE

Press [ENTER] to access the {Set Time and Date} sub-menu.

- Flashing in the upper left hand corner of the display should be {24 HR}, which denotes a 24 hour clock. By pressing [UP], you can change this to a 12 hour {12 HR} clock.



THE 12 HOUR CLOCK SELECTION WILL ADD AN 'a' OR 'p' AFTER THE TIME.

Press [ENTER] to accept the desired time format.

12 HR 2:31a	MM/DD/YY 1/22/01
----------------	---------------------

- The time will now be flashing with the cursor located under the hour position. Press [UP] or [DOWN] to adjust the time to your local time.

12 HR	MM/DD/YY
<u>2</u> :31a	1/22/01



THE CURSOR LOCATED UNDER THE DIGIT IN THE TIME, INDICATES THE CHARACTER BEING CHANGED.

Once the hour is set, press [ENTER] and the cursor will move to the first digit in the minute setting. Press [UP] or [DOWN] to set the correct tens of minutes digit, then press [ENTER].

12 HR	MM/DD/YY
2: <u>3</u> 1a	1/22/01

- The cursor moves to the second digit of the minute setting. Press [UP] or [DOWN] to set the correct second minute digit, then press [ENTER].

12 HR	MM/DD/YY
2:3 <u>1</u> a	1/22/01

- If you selected the 12 hour format, the cursor moves under the a.m./p.m. character. Press [UP] or [DOWN] to set the correct a.m./p.m. character (a or p), then press [ENTER].

12 HR	MM/DD/YY
2:31 <u>a</u>	1/22/01

- The date format will now be flashing on the display. The date can be expressed in one of three formats: MM/DD/YY, DD/MM/YY, YY/MM/DD.

Press [UP] or [DOWN] to scroll through the above referenced formats. When the format you desire is displayed, press [ENTER] to accept this format and continue.

- The date is now flashing on the display. Press [UP] or [DOWN] to change this to the current date. Press [ENTER] to accept this value and the cursor moves to the next date position. Continue to press [UP] or [DOWN]. Press [ENTER] on the last date field to accept your setting.

12 HR	MM/DD/YY
2:31 A	<u>1</u> /22/01



YOU ARE NOT ALLOWED TO EXIT THE DATE FIELD IF THE DATE DOES NOT EXIST. FOR EXAMPLE, JUNE 31 OR FEB 29 IN A NON- LEAP YEAR WOULD NEED TO BE CORRECTED TO A VALID DATE.

- The DLC prompts you to change the time and date for {DAYLIGHT SAVINGS / NO}. Press [UP] to scroll to {AUTO CHANGE}. The auto-change option complies with daylight savings time changes as mandated by United States legislation. Press [ENTER] to accept the correct configuration based on the location of the DLC.

DAYLIGHT SAVINGS
AUTO CHANGE



THE TIMES CHANGE OVER ON THE FIRST SUNDAY IN APRIL AND ON THE LAST SUNDAY IN OCTOBER.

9. If "AUTO CHANGE" was selected in the previous step, the DLC prompts you for the current day of the week. Press [UP] to scroll through the days of the week. Press [ENTER] to accept the current day of the week.

DAY OF THE WEEK
WEDNESDAY

10. The DLC prompts you to accept the time and date programmed in the above referenced steps. {CONFIRM CHANGE? / YES}. Press [ENTER] to accept. If you do not want to accept the new inputs, press [UP] to scroll to {NO} and press [ENTER].

CONFIRM CHANGE?
YES

11. The display will return to the {-MENU- / SET TIME & DATE} screen.

7.2.4 Analog Signal Failure Setup

This sub-menu allows you to set up the DLC response if the analog signal fails. You can program the DLC to have one of the following responses:

- Freeze at the last good analog input signal,
- Shut the motor off,
- Go to a default signal.

An analog input failure is detected if one of the following conditions occurs. First, the signal falls below the lower calibrated range by 0.3mA. For example, if the DLC is calibrated with a range of 4-20mA and the signal falls to 3.6mA, then a failure is recognized. Second, if the analog signal falls below 0.3mA and is changing at a rate of 8.8mA per second or more, a failure will be logged. This second condition is primarily for the situation where the input is calibrated down to 0 (0.0mA).

When an Analog Input is calibrated in the 0-5mA or 0-20mA range and you are operating down near the lower end (<2.5mA) the detection of a failed signal may not occur because the slew rate (rate of change) is too low to be detected. If you are calibrated down to 0mA, operation after a failure will be restored immediately because 0mA is an in-range signal. In this case you should use the MOTOR OFF option rather than FREEZE or GO TO DEFAULT choices.



IF ANALOG INPUT SIGNAL FAILURE IS IMPORTANT TO OPERATION, AVOID CALIBRATING TO 0 MA.



SIGNAL FAILURE RESPONSE SETUP PROCEDURE

1. Press [MENU] and press [UP] or [DOWN] until {-MENU- / ANALOG SIG FAIL} is displayed.

- MENU -
ANALOG SIG FAIL

Press [ENTER] to continue to the Analog Signal Fail setup screens.

The first entry in the Analog Signal Failure menu determines how the DLC recovers from a failed analog input. You can select from two {RESTORE

TO:} modes: Analog or Manual. If {ANALOG MODE} is selected, the DLC will resume automatically following the 4-20mA input. If {MANUAL MODE} is selected, the DLC will enter the manual mode as soon as the signal loss is detected. It will remain in Manual Mode until it is changed manually (press [MODE] on the front panel). The benefit of using a {RESTORE TO: / ANALOG MODE} is that it's totally automatic. If so programmed, the DLC can shut itself down, wait for a signal to return, and then start itself back up.

Press [ENTER] to accept the factory default of {RESTORE TO: / ANALOG MODE} or press [UP] and then press [ENTER] to select the {RESTORE TO: / MANUAL MODE}.

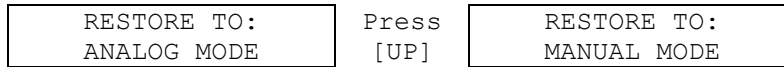

- The menu for having the DLC freeze at the last signal is displayed.

ANALOG SIG FAIL FREEZE @ LAST SIG

To accept this action, press [ENTER]. Go to step 5.

- If you desire a different action, press [UP]. The menu for having the DLC shut the motor off is displayed.

ANALOG SIG FAIL MOTOR OFF

To accept this action, press [ENTER]. Go to step 5.

- If you desire a different action, press [UP]. The menu for having the DLC go to a default signal (e.g.: 10%) is displayed.

ANALOG SIG FAIL GO TO DEFAULT

To accept this action, press [ENTER].

- The next display prompts for the uncalibrated percent of flow to be the default setting. Enter the value using [UP] or [DOWN].

SIGNAL DEFAULT 10.0%

To accept this value, press [ENTER].

- The {ERROR MESSAGE / ENABLED} screen is displayed.

ERROR MESSAGE ENABLED

To accept this value, press [ENTER] and the {-MENU- / ANALOG SIG FAIL} screen is displayed.

If you desire a different action, press either [UP] or [DOWN] to display the {ERROR MESSAGE / DISABLED} screen.

ERROR MESSAGE DISABLED

To accept this value, press [ENTER] and the {-MENU- / ANALOG SIG FAIL} screen is displayed.



THE ERROR WILL STILL BE LOGGED WITH THE TIME AND DATE, BUT THE FLASHING ERROR MESSAGE ON THE SCREEN IS SUPPRESSED. THIS IS FOR APPLICATIONS THAT INTENTIONALLY INTERRUPT THE ANALOG SIGNAL IN THE NORMAL COURSE OF OPERATIONS, STOPPING AND RE-STARTING THE PUMP.

7.2.5 MODBUS Signal Failure Setup

This sub-menu allows you to set up the DLC response if the MODBUS Signal fails. You can program the DLC to have one of the following responses:

- Freeze at the last digital input signal,
- Shut the motor off,
- Go to a default setting.

A MODBUS Signal failure is detected if the DLC does not receive a valid message sent to its address within the timeout setting.



MODBUS SIGNAL FAURE SETUP PROCEDURE.

1. Press [MENU] and press [UP] or [DOWN] until the display reads {-MENU- / MODBUS SIG. FAIL}.

- MENU -
MODBUS SIG FAIL

Press [ENTER] to continue to the MODBUS Signal Fail sub-menus.

2. The {RESTORE TO:} menu is displayed. This setting determines how the DLC will recover from a failed MODBUS Signal. You can select from two {RESTORE TO:} modes – MODBUS or Manual.

If {MODBUS MODE} is selected the DLC will resume following the MODBUS signal automatically when the signal is restored.

If {MANUAL MODE} is selected, the DLC will enter manual mode as soon as the signal loss is detected. The DLC will remain in Manual Mode until it is changed manually (press [MODE] on the front panel).

The benefit of using {RESTORE TO: / MODBUS MODE} is that it's totally automatic. If so programmed, the DLC can shut itself down, wait for the signal to return and then start itself back up.

RESTORE TO:
MODBUS MODE

Press
[UP]

RESTORE TO:
MANUAL MODE

Press [ENTER] to accept the factory default of {RESTORE TO: / MODBUS MODE} or press [UP] and then press [ENTER] to select the {RESTORE TO: / MANUAL MODE}.

3. The next entry in the MODBUS SIG. FAIL sub-menu allows you to set the timeout value in seconds. This defines the maximum interval between messages addressed to this node. If a message is not received within this period, a MODBUS Signal failure will be detected. A number of factors influence the value you should set here:
 - 1) Number of nodes on the network
 - 2) Type of master
 - 3) Baud rate
 - 4) Electrical environment.

Here are some general guide lines:

- Increase this value as you increase the number of nodes on the network.
- Increase this value as you decrease the communications baud rate.
- Increase this value if the DLC is a slave connected to a heavily loaded PC/PLC master.
- Increase this value if you are in an electrically noisy environment.
- Decrease this value if the DLC is mission critical on a small (2-3 node) network.



ALWAYS USE THE DEFAULT SETTING (2.5 SECONDS) AS A STARTING POINT. TO ADJUST THE VALUE, PRESS [UP] OR [DOWN], PRESS [ENTER] TO ACCEPT THE VALUE.

```
TIMEOUT
2.5 SECONDS
```

The screens to be displayed next are dependent on how your DLC Serial Communications (ACTIVE) and MODBUS mode have been configured.

The menu that selects the MODBUS Signal failure action is displayed. There are three available options:

- 1) Freeze at last signal
- 2) Motor off
- 3) Go to Default

Press [UP] or [DOWN] to select the desired option. Press [ENTER] to accept your setting.

```
MODBUS SIG FAIL FREEZE @ LAST SIG  Press [UP]  MODBUS SIG FAIL MOTOR OFF  Press [UP]  MODBUS SIG FAIL GO TO DEFAULT
```

4. If you selected {FREEZE @LAST SIG} or {MOTOR OFF} in step 4, proceed to step 6. If you selected {GO TO DEFAULT}, you must set the default value.

Press [UP] or [DOWN] to set the default signal in percent.

```
SIGNAL DEFAULT
10.0%
```

Press [ENTER] to accept your setting.

5. The {ERROR MESSAGE} screen is displayed. Press [UP] or [DOWN] to select between {ENABLED} or {DISABLED}

```
ERROR MESSAGE ENABLED  Press [UP]  ERROR MESSAGE DISABLED
```

Press [ENTER] to accept your setting.



WHEN THE DISABLED SETTING IS SELECTED, THE ERROR WILL STILL BE LOGGED WITH THE DATE AND TIME, BUT THE FLASHING ERROR MESSAGE ON THE SCREEN WILL BE SUPPRESSED. THIS OPTION IS FOR APPLICATIONS THAT INTENTIONALLY INTERRUPT THE MODBUS SIGNAL IN THE NORMAL COURSE OF OPERATIONS, STOPPING AND RE-STARTING THE PUMP.

7.2.6 Leak-Detection Failure Setup

This sub-menu allows you to configure the DLC to interact with a PULSAlarm Leak-Detection Diaphragm. You can modify the way the DLC responds to a diaphragm rupture. The following responses are available:

- Shut the motor off,
- Trigger an alarm relay,
- Shut the motor off and trigger an alarm relay,
- Have no interaction with the Pump Motor or Alarm Relay other than log the diaphragm failure and display a message on the LCD display (this message is displayed until a key on the keypad is pressed).



THE LEAK SENSOR SWITCH MUST BE A DRY CONTACTING TYPE. REFER TO SECTION 5: INSTALLATION, LOW-VOLTAGE INPUT CONNECTIONS FOR WIRING INFORMATION.

IF YOU SELECT THE 'MOTOR OFF' OPTION, THE MOTOR WILL HAVE TO BE MANUALLY RE-STARTED IF A FAILURE IS DETECTED (I.E., PRESS [MOTOR] TO START THE PUMP MOTOR).



LEAK-DETECTION FAILURE SETUP PROCEDURE

1. Press [MENU] to enter the { –MENU– } sub-system. Press [UP] or [DOWN] until { –MENU– / LEAK DETECTION } is displayed.

```
  - MENU -  
LEAK DETECTION
```

Press [ENTER] to continue to program the Leak-Detection options.

2. The Leak-Detection Input can be configured as {INACTIVE}. If the pump is not supplied with a PULSAlarm Leak-Detection Diaphragm, it should be set as {INACTIVE}.

```
LEAK DET INPUT  
INACTIVE
```

Press [ENTER] to accept your selection. The { –MENU– / LEAK-DETECTION } screen is displayed.

3. If your pump is supplied with a PULSAlarm Leak-Detection Diaphragm, press [UP] to select the type of switch. The Leak-Detection Input switch can be configured as {NORMALLY OPEN},

```
LEAK DET INPUT  
NORMALLY OPEN
```

Or press [UP] to configure the switch as {NORMALLY CLOSED}.

```
LEAK DET INPUT  
NORMALLY CLOSED
```

Press [ENTER] to accept the desired configuration.



THE SETTING NORMALLY OPEN MEANS THE CIRCUIT WILL BE OPEN DURING NORMAL OPERATION AND CLOSED WHEN THE DIAPHRAGM FAILS.

4. The display prompts you to configure the motor state (ON/OFF) should a diaphragm rupture occur (i.e., a leak is detected).

```
LEAK DETECTION
MOTOR OFF? NO
```

If you do not want the pump's motor to turn off when a leak is detected, press [ENTER] to accept the default value. If you want the motor to shut off if a leak is detected, press [UP] to scroll to {YES} and press [ENTER].

5. The display prompts you to configure the alarm relay status (triggered or not triggered).

```
LEAK DETECTION
ALARM RELAY? NO
```

If you do not want the Alarm Relay activated when a leak is detected, press [ENTER] to accept the default of {NO}. If you want the alarm relay to be active if a leak is detected, press [UP] to scroll to {YES} and press [ENTER]. The display returns to the { –MENU– / LEAK- DETECTION} screen.

7.2.7 Level / Remote Start-Stop Setup

This sub-menu allows you to configure the DLC to interact with a level input. You can program the DLC to have one of the following responses:

- Shut the motor off,
- Trigger the alarm relay,
- Shut the motor off and trigger the alarm relay,
- Shut the motor OFF when the level input is in one state (e.g. CLOSED) and turn the motor ON when the level input is in the other state (e.g. OPEN).



THE LEVEL SENSOR OR START/STOP SWITCH MUST BE A DRY CONTACTING TYPE. REFER TO SECTION 5: INSTALLATION, LOW-VOLTAGE INPUT CONNECTIONS.

IF YOU SELECT THE 'MOTOR OFF' OPTION, THE MOTOR WILL HAVE TO BE MANUALLY RE-STARTED WHEN A LEVEL FAILURE IS DETECTED (I.E., PRESS [MOTOR] TO START THE PUMP MOTOR).



LEVEL/START-STOP SETUP PROCEDURE

1. Press [MENU] to enter the { –MENU – } sub-system. Press [UP] or [DOWN] until { –MENU– / LEVEL SWITCH } screen is displayed.

```
  - MENU -  
LEVEL SWITCH
```

Press [ENTER] to continue to program the Level Switch sub-menu.

2. The level input can be configured as {INACTIVE}, if it will not be used.

```
LEVEL SWITCH  
INACTIVE
```

Pressing [ENTER] when {LEVEL SWITCH / INACTIVE} is displayed will cause the screen to return to the { –MENU– / LEVEL SWITCH } screen.

3. Press [UP] to scroll to the next option {LEVEL SWITCH / ACTIVE}.

```
LEVEL SWITCH  
ACTIVE
```

4. Press [ENTER] when {LEVEL SWITCH / ACTIVE} is displayed and the following screen is displayed.

```
LEVEL SWITCH  
DRUM LEVEL
```

Select this option if the level input is to be connected to a drum level switch. Press [ENTER] to select. Go to step 7.



THE NORMAL STATE FOR DRUM LEVEL REFERS TO THE CONDITION THAT EXISTS WHEN THE DRUM LEVEL IS OK AND THE PUMP SHOULD BE RUNNING. FOR EXAMPLE, IF THE DRUM LEVEL SWITCH CLOSURES WHEN THE DRUM IS FULL (AND THE PUMP SHOULD BE RUNNING) THEN THE NORMAL STATE IS CLOSED.

5. Pressing [UP] when the {LEVEL SWITCH / DRUM LEVEL} screen is

displayed will open the {LEVEL SWITCH / START/STOP} screen.

LEVEL SWITCH
START/STOP



THE NORMAL STATE FOR START/STOP, REFERS TO THE CONDITION THAT EXISTS WHEN THE START/STOP (CALL TO RUN) SIGNAL IS OK AND THE PUMP SHOULD BE RUNNING. FOR EXAMPLE, IF THE START/STOP SWITCH CLOSSES WHEN THE PUMP IS EXPECTED TO RUN THEN THE NORMAL STATE IS CLOSED.

6. Pressing [ENTER] from {LEVEL SWITCH / START/STOP} screen to configure the LEVEL SWITCH input for use with a remote motor On/Off switch.
7. The Level Switch Configuration screen is displayed:

LEVEL SWITCH
NORMALLY CLOSED

8. Press [ENTER] to configure the switching device as {NORMALLY CLOSED}, or press [UP] and then press [ENTER] to configure the switching device as {NORMALLY OPEN}.



WHEN {LEVEL SWITCH / START/STOP} HAS BEEN SELECTED, YOU ARE RETURNED TO THE {-MENU- / LEVEL SWITCH} SCREEN. THIS SETTING USES THE DEFAULT SETTINGS OF {MOTOR OFF? / YES} AND {ALARM RELAY / NO}. THESE SETTINGS CANNOT BE MODIFIED.

9. The display prompts for the motor status when the Level Input trips:

LEVEL SWITCH
MOTOR OFF? YES

Press [ENTER] if you want the PULSAR motor to turn off when the Drum Level input is sensed. Go to step 11.

10. If you want the PULSAR motor to stay on when a Drum Level is sensed, press [UP] to scroll to {NO}.and press [ENTER].

LEVEL SWITCH
MOTOR OFF? NO

11. The display prompts you for the alarm relay status should the Drum Level Input trigger the alarm relay.

LEVEL SWITCH
ALARM RELAY? YES

Press [ENTER] if you want the Alarm Relay to activate with the Drum Level Input. The display returns to the {-MENU- / LEVEL SWITCH} screen.

12. If you do not want the Alarm Relay to activate with the Level Switch Input, press [UP] to scroll to {NO}.

LEVEL SWITCH
ALARM RELAY? NO

Press [ENTER] to accept the setting. The display returns to the {-MENU- / LEVEL SWITCH} screen.

7.2.8 Digital Output Setup

This sub-menu allows you to determine if the Digital Output is to be used as a counter for pump strokes, as a remote motor on/off indicator, or for Mode indication.

For example: If the Digital Output is set up as {RUN/STOP STATUS}, and {DIGITAL OUTPUT / NORMALLY OPEN} it will activate when the motor is on and deactivate when the motor is off.

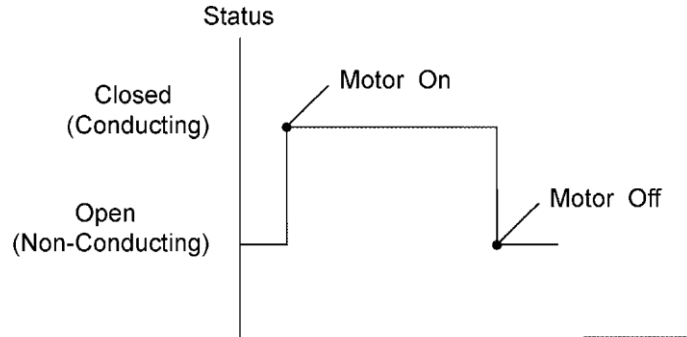

Figure 17 – Run/Stop Status

If the Digital Output is set up as {PUMP STROKE}, it will activate for 50% of each stroke and deactivate for 50% of each stroke.

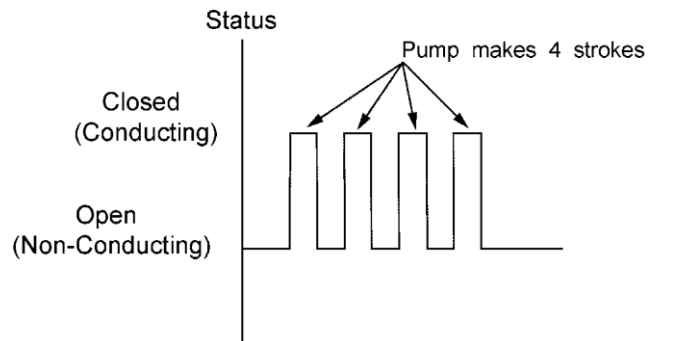

Figure 18 – Pump Stroke Status

If the Digital Output is set up as {MODE INDICATION / ANALOG MODE}, and {DIGITAL OUTPUT / NORMALLY OPEN} it will activate when the mode is set to {ANALOG} and deactivate in any other (e.g., {MANUAL MODE}) mode.

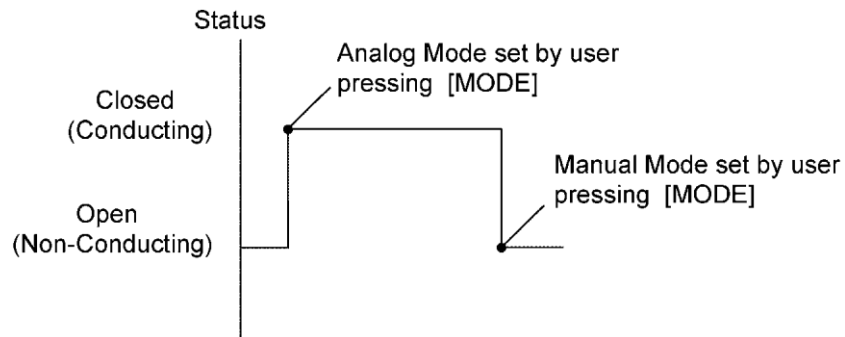

Figure 19 – Mode Indication



DIGITAL OUTPUT SETUP PROCEDURE

1. Press [MENU] once and then press [UP] or [DOWN] until the display reads {-MENU- / DIGITAL OUTPUT}.

```

- MENU -
DIGITAL OUTPUT

```

2. Press [DOWN]. The {DIGITAL OUTPUT / RUN/STOP STATUS} screen is displayed.

```

DIGITAL OUTPUT
RUN/STOP STATUS

```

To use the DIGITAL OUTPUT function as a remote On/Off indication, press [ENTER]. Go to step 5.

3. Press [ENTER] to continue to program the Digital Output sub-menu. The {DIGITAL OUTPUT / PUMP STROKE} screen is displayed.

```

DIGITAL OUTPUT
PUMP STROKE

```

To use the DIGITAL OUTPUT to indicate pump strokes, press [ENTER]. Go to step 5.

4. Press [DOWN]. The {DIGITAL OUTPUT / MODE INDICATION} screen is displayed.

```

DIGITAL OUTPUT
MODE INDICATION

```

To use the DIGITAL OUTPUT function as a Mode Indicator press [ENTER]. The following screens are displayed:

MODE INDICATION MANUAL MODE	Press [UP]	MODE INDICATION ANALOG MODE	Press [UP]	MODE INDICATION MODBUS MODE
--------------------------------	---------------	--------------------------------	---------------	--------------------------------

Press [UP] or [DOWN] to scroll through the screens shown above. Press [ENTER] to select the desired option.

5. The {DIGITAL OUTPUT / NORMALLY OPEN} screen is displayed.

In this mode, the output is open (non-conducting) when the motor is off or the Mode is wrong.

```

DIGITAL OUTPUT
NORMALLY OPEN

```

The output is closed (conducting) when the motor is on or the Mode is correct. Configure the output as {NORMALLY OPEN} by pressing [ENTER]. Go to step 7.

6. Press [UP] to open the {DIGITAL OUTPUT / NORMALLY CLOSED} screen.

In this mode, the output is open (non-conducting) when the motor is on or the Mode is correct.

```

DIGITAL OUTPUT
NORMALLY CLOSED

```

The output is closed (conducting) when the motor is off or the Mode is wrong. Press [ENTER] to configure the output as {NORMALLY CLOSED}.

7. The {-MENU- / DIGITAL OUTPUT} screen is displayed.

7.2.9 Motor Thermostat Setup

This sub-menu allows you to configure the DLC to interact with the pump motor thermostat. Depending on the application, it is possible for the fan cooled pump motor to run at low RPM and high torque, which degrades the effectiveness of the fan and can cause heat buildup.

For equipment safety, the DLC can be programmed to have one of the following responses if the Motor Thermostat activates:

- Shut the motor off (no alarm) (no restart)
- Trigger the alarm relay (motor stays on)
- Shut the motor off and trigger the alarm relay (no restart)
- Shut the motor off, trigger the alarm relay, and then restart the motor when the Motor Thermostat resets
- Shut the motor off and then restart the motor when the Motor Thermostat resets (No alarm),
- Ignore the thermostat input. (not recommended)



MOTOR THERMOSTAT SETUP PROCEDURE

1. Press [MENU] once and then press [UP] or [DOWN] until the display reads {-MENU- / MOTOR THERMOSTAT}.

```
- MENU -  
MOTOR THERMOSTAT
```

2. Press [ENTER] and the {MOTOR THERMOSTAT / NORMALLY CLOSED} screen is displayed.

```
MOTOR THERMOSTAT  
NORMALLY CLOSED
```

Press [ENTER] to accept the {NORMALLY CLOSED} configuration. Go to step 3.

Or

Press [UP] and the {MOTOR THERMOSTAT / INACTIVE} screen is displayed.

```
MOTOR THERMOSTAT  
INACTIVE
```

If the {MOTOR THERMOSTAT} is to be configured as {INACTIVE}, press [ENTER] and you are returned to the {-MENU- / MOTOR THERMOSTAT} screen.



IF YOU SET {MOTOR THERMOSTAT} TO {INACTIVE} IT IS POSSIBLE FOR THE MOTOR WINDINGS TO OVERHEAT LEADING TO PREMATURE MOTOR FAILURE AND POSSIBLE HAZARDOUS CONDITIONS (E.G., FIRE).

3. Pressing [UP] from the {MOTOR THERMOSTAT / INACTIVE} screen will display the {MOTOR THERMOSTAT / NORMALLY OPEN} screen.

```
MOTOR THERMOSTAT  
NORMALLY OPEN
```

Press [ENTER] to accept the {NORMALLY OPEN} configuration.

- The {MOTOR THERMOSTAT / MOTOR OFF? YES} screen is displayed.

```
MOTOR THERMOSTAT
MOTOR OFF? YES
```

Press [UP] to select between {YES} or {NO}.

If you want the motor to turn off when the thermostat activates, (recommended), set {MOTOR OFF?} to {YES}.

Press [ENTER] to accept the desired configuration.



IF YOU SET {MOTOR OFF?} TO {NO} IT IS POSSIBLE FOR THE MOTOR WINDINGS TO OVERHEAT LEADING TO PREMATURE MOTOR FAILURE AND POSSIBLE HAZARDOUS CONDITIONS (E.G., FIRE).

- The {MOTOR THERMOSTAT / ALARM RELAY? YES} screen is displayed.

```
MOTOR THERMOSTAT
ALARM RELAY? YES
```

Press [UP] to select between {YES} and {NO}.

```
MOTOR THERMOSTAT
ALARM RELAY? NO
```

Press [ENTER] to accept the desired configuration.

- If {MOTOR THERMOSTAT / MOTOR OFF? YES} is selected in step 4, the {RESTORE TO: / MOTOR ON} screen is displayed.

```
RESTORE TO:
MOTOR ON
```

If you want the DLC to turn the motor back on when the thermostat deactivates, set {RESTORE TO:} to {MOTOR ON}. Press [UP] to select between {MOTOR ON} and {MOTOR OFF}. Press [ENTER] to accept your setting.

```
RESTORE TO:
MOTOR OFF
```

- The display will return to the {-MENU- / MOTOR THERMOSTAT} screen.

7.2.10 Over Temperature Setup

This sub-menu allows you to disable the warning message when the DLC's internal temperature approaches its operating limit of 70°C / 158°F. The error condition will not reset until the temperature drops below 65°C / 149°F. The difference between the trip and release point is 5°C / 9°F.



RUNNING THE DLC AT ELEVATED TEMPERATURES COULD RESULT IN IMPROPER AND DANGEROUS OPERATION.



THIS WARNING DOES NOT AFFECT THE OPERATION OF THE DLC, IT IS FOR YOUR INFORMATION ONLY. DISABLING THIS FLASHING WARNING MESSAGE DOES NOT INHIBIT THE LOGGING OF THE DIAGNOSTIC TIME AND DATE OF THE EVENT.



OVER TEMPERATURE SETUP PROCEDURE

1. Press [MENU] once and then [UP] or [DOWN] until the display reads {–MENU– / OVER TEMPERATURE}.

```

- MENU -
OVER TEMPERATURE
  
```

Press [ENTER] to go to the Over Temperature response sub-menu.

2. The {OVER TEMPERATURE / ENABLED} (system default) screen is displayed.

```

OVER TEMPERATURE
ENABLED
  
```

3. Press [ENTER] to accept the {ENABLED} setting and you are returned to the {–MENU– / OVER TEMPERATURE} screen. **or**

Press [UP] to display the {OVER TEMPERATURE / DISABLED} screen.

```

OVER TEMPERATURE
DISABLED
  
```

Press [ENTER] to accept the {DISABLED} setting. The display will return to the {–MENU– / OVER TEMPERATURE} screen.

```

- MENU -
OVER TEMPERATURE
  
```

7.2.11 Power Failure Setup

This sub-menu allows you to configure the way the DLC reacts when power is restored after a power outage. Additionally this sub-menu allows setting the action to take if improper voltage is applied.

During the power up stage, the DLC can either:

- Return to settings that were active when the pump lost power.
- Shut the motor off.



A POWER OUTAGE IS DEFINED AS THE LOSS OF POWER WHENEVER THE DLC IS NOT IN THE {MOTOR OFF} STATE.



POWER FAILURE SETUP PROCEDURE

1. Press [MENU] once and then [UP] or [DOWN] until the display reads {–MENU– / POWER FAILURE}.

```

- MENU -
POWER FAILURE
  
```

Press [ENTER] to go the power failure response sub-menu.

2. The display prompts you for the {Power-up} status. To shut the motor off

when the power is returned to the unit (after a power failure), select the {MOTOR OFF} option (factory default).

DURING POWER UP
MOTOR OFF

Press [ENTER] to accept. Go to step 4.

- If you want to return to the prior settings, press [UP] and scroll to {DURING POWER UP / PRIOR SETTINGS}.

DURING POWER UP
PRIOR SETTINGS

Press [ENTER] to accept.

- The display prompts you for an action to take when the wrong voltage is detected.

WRONG VOLTAGE
HARD SHUT DOWN

The following options are available:

SELECTION	ACTION
Hard Shutdown	Display under/over voltage message
	Turn motor off
	Inhibit motor operation (Motor Key Disabled)
	Voltage correction and power cycle required to reset
Motor Off	Display under/over voltage message
	Turn motor off
Message Only	Display under/over voltage message
Ignore Error	None

Press [UP] or [DOWN] to make your selection. Press [ENTER] to accept your selection.

- The display will return to the {-MENU- / POWER FAILURE} screen.

7.2.12 Alarm Relay

This sub-menu sets up the alarm relay outputs as normally open or normally closed.



THESE SCREENS CONFIGURE BOTH THE HIGH-VOLTAGE OUTPUT AND LOW-VOLTAGE SWITCH (TRANSISTOR).



ALARM RELAY SETUP PROCEDURE

- Press [MENU]. Press [UP] or [DOWN] until {-MENU- / ALARM RELAY} is displayed. Press [ENTER] to continue to program the Alarm Relay sub-menu.

- MENU -
ALARM RELAY

- The alarm relay can be configured as {NORMALLY OPEN}. With this setting the relay will CLOSE when the alarm output is activated.

RELAY OUTPUT
NORMALLY OPEN

If you would rather have the relay OPEN when the output is activated, press [UP] to change the configuration to {NORMALLY CLOSED}.

RELAY OUTPUT
NORMALLY CLOSED

When you have finished making your selection, press [ENTER] to accept.

3. The display returns to the {-MENU- / ALARM RELAY} screen.

7.2.13 Analog Mode

Use the Analog Mode setting to activate or de-activate the analog mode and set the number of active signals. If deactivated, the analog mode will not appear when the [MODE] key is pressed. If you are not using the analog input (i.e., you have made no connections to J4-1, J4-2) but have the Analog Mode set to ACTIVE then any time you press [MODE], by default the DLC will generate an {ANALOG SIG FAIL} alarm. De-activating Analog Mode prevents this.

You can modify the way the DLC responds to a signal. You can set the number of samples to be averaged (within a range of 1 to 100 samples), and you can set the interval, in number of samples, that the DLC should adjust the stroke setting to the specified average (within a range of 1 to 100 samples). The DLC samples the Analog Input every 0.25 seconds. The default value for the number of samples is 20 and the default value for the sample interval is 20. Therefore, the DLC will average the last 20 samples and make an adjustment every 5 seconds ($20 \times 0.25 = 5.0$). Here are some general guidelines to assist you when adjusting these values:

- Increase the {SAMPLE SIZE} value to reduce the effect of electrical noise on the Analog Input.
- Decrease the {SAMPLE SIZE} value to increase sensitivity to changes in the Analog Input.
- Increase the {UPDATE EVERY / XX SAMPLES} value if the DLC is constantly adjusting the stroke setting (often resulting in a {DUTY CYCLE} alarm).
- Decrease the {UPDATE EVERY / XX SAMPLES} value to increase tracking response.



IN MOST SITUATIONS, THE DEFAULT VALUES WILL BE ADEQUATE.

ANALOG MODE SETUP PROCEDURE

1. Press [MENU] once and then [UP] or [DOWN] until the screen {-MENU- / ANALOG MODE} is displayed.

- MENU -
ANALOG MODE

Press [ENTER] to continue to program the Analog Mode sub-menu.

2. The {ANALOG MODE / ACTIVE} screen is displayed.

ANALOG MODE
ACTIVE

Press [ENTER] to accept the default value.

If you want the analog mode to be inactive and {ACTIVE} is displayed, press [UP] to change the display to {INACTIVE}. Press [ENTER] to accept your selection. Go to step 6.

3. The {SAMPLE SIZE / XXX} screen is displayed.

SAMPLE SIZE XXX

Press [UP] or [DOWN] to set the number of samples taken from the 4-20mA input to average. The DLC will adjust its output in accordance with the average of the number of samples you set here. Enter a value in the range of 1 to 100 samples using the [UP] or [DOWN] key(s).

Press [ENTER] to accept the entry.



INCREASE THE NUMBER OF SAMPLES TO SMOOTH OUT A NOISY INPUT. DECREASE THE NUMBER OF SAMPLES TO CAUSE THE DLC TO TRACK A RAPIDLY CHANGING SIGNAL MORE CLOSELY.

4. The {UPDATE EVERY / XXX SAMPLES} screen is displayed. Press [UP] or [DOWN] to set how often the DLC will adjust to the current average value. The default value (20) causes the DLC to adjust every 20 samples or every 5 seconds ($20 * 0.25 = 5$). You may enter a value in the range of 1 to 100 using the [UP] or [DOWN] key(s).



DECREASE THE VALUE TO BETTER FOLLOW A RAPIDLY CHANGING SIGNAL.

UPDATE EVERY XXX SAMPLES

5. Press [ENTER] to accept your selection.
6. The {-MENU- / ANALOG MODE} screen is displayed.

7.2.14 MODBUS Mode

Use the MODBUS mode setting to activate or de-activate the DLC's ability to follow a MODBUS serial signal. If deactivated, the MODBUS mode will not appear when [MODE] is pressed. If you are not using the serial input (i.e., you have made no connections to J7 or J8) but have the MODBUS mode set to active, then any time you mistakenly press [MODE], by default the DLC will generate a {MODBUS SIGNAL FAILURE} alarm. De-activating MODBUS mode prevents this.



THE [MODE] KEY ALLOWS YOU TO SELECT AN OPERATING MODE. IT ACTS AS A MASTER SWITCH ALLOWING YOU TO SELECT THE SIGNAL THAT CONTROLS THE DLC. IT DOES NOT INHIBIT MODBUS COMMUNICATIONS. IT ONLY INHIBITS MODBUS COMMANDS THAT PERTAIN TO THE OPERATION (E.G., YOU CANNOT TURN THE PUMP MOTOR ON USING MODBUS UNLESS THE MODE IS SET TO MODBUS).



MODBUS MODE SETUP PROCEDURE:



TO ACCESS THE {MODBUS MODE} MENU YOU MUST HAVE SERIAL COMM ENABLED AND THE CLASS SET TO SLAVE. REFER TO THE SERIAL COMMUNICATIONS SECTION LATER IN THIS CHAPTER.

1. Press [MENU]. Press [UP] or [DOWN] until the {-MENU- / MODBUS MODE} screen is displayed.

```

- MENU -
MODBUS MODE

```

Press [ENTER] to continue to program the MODBUS mode. The {MODBUS MODE / INACTIVE} screen is displayed.

```

MODBUS MODE
INACTIVE

```

{MODBUS MODE / INACTIVE} would be selected if you do not intend to control the DLC using the MODBUS protocol. Pressing [ENTER] when {INACTIVE} is displayed will cause the screen to return to the {-MENU- / MODBUS MODE} menu.

2. {MODBUS MODE / ACTIVE} would be selected if you are going to control the DLC using the MODBUS protocol.

With the {MODBUS MODE / INACTIVE} screen displayed, press [UP] to display the {MODBUS MODE / ACTIVE} screen.

```

MODBUS MODE
INACTIVE

Press [UP]

MODBUS MODE
ACTIVE

```

Press [ENTER] to accept the {ACTIVE} setting.

3. The {INPUT RATIO / 100%} screen is displayed.
4. Use the {INPUT RATIO} setting to scale the serial input value to meet your needs. Press [UP] or [DOWN] to set the ratio value between 20% and 100%.

```

INPUT RATIO
100%

```

Press [ENTER] to accept your changes. The {ACTION / FORWARD} screen is displayed.

5. You can also instruct the DLC to act on the MODBUS signal in a forward or reverse direction. When {ACTION / FORWARD} is selected, the DLC “acts” in the same direction as the signal. If the signal changes from 25% to 75%, the DLC will adjust its output from 25% to 75% (assuming the ratio is set to 100%). When {ACTION / REVERSE} is selected the DLC will “act” in the opposite direction. If the signal changes from 25% to 75% the DLC will adjust its output from 75% to 25% (assuming the ratio is set to 100%).

Press [UP] or [DOWN] to switch between {ACTION / FORWARD} and {ACTION / REVERSE}.

```

ACTION
FORWARD

Press [UP]

ACTION
REVERSE

```

Press [ENTER] to accept your selection.

6. The {-MENU- / MODBUS MODE} screen is displayed.

7.2.15 Security

The DLC has three modes of security:

1. None (OFF)
2. Tamper Proof
3. Calibration

With Tamper Proof security active, the DLC will lockout all of the front panel keys with the exception of [MOTOR]. To use any other key you will be prompted to enter a four digit Personal Identification Number (PIN). Successful entry of a PIN allows you to access all DLC functions without PIN re-entry. With Calibration security set, the DLC will lockout access to the [CAL] sub- menu, Pin Setup and Factory Reset Ability. To use [CAL] you must first enter your PIN. Successful entry of a PIN allows you to access the {CALIBRATE} menu.



THE SECURITY MODE RE-SETS AFTER 5-MINUTES OF KEYPAD IN-ACTIVITY.



SECURITY SETUP PROCEDURE

1. Press [MENU]. Press [UP] or [DOWN] until {-MENU- / SECURITY} is displayed. Press [ENTER] to continue to program the Security sub-menu.

```
- MENU -  
SECURITY
```

2. The type of security available appears flashing on the display. If no password security protection is desired, press [ENTER] and go to step 8.

```
SECURITY TYPE  
OFF
```

3. Press [UP] and the {TAMPER PROOF} option is displayed. If complete tamper proof security of all settings is required, press [ENTER] and go to step 5.

```
SECURITY TYPE  
TAMPER PROOF
```

4. Press [UP] and the {CAL SETTINGS} option is displayed. If security protection of only the calibration settings is desired, press [ENTER].

```
SECURITY TYPE  
CAL SETTINGS
```

5. The display prompts you to enter a four digit pin number. A line under the first digit indicates the character to be changed. Press [UP] and [DOWN] to scroll through the numbers 0-9. Press [ENTER] to accept the desired number. The line then moves to beneath the second digit. Continue to press [UP], [DOWN] and [ENTER] to set the four digit password.



THE VALUES YOU ENTER ARE VISIBLE TO BOTH YOURSELF AND ANYONE ELSE WHO MAY BE WATCHING YOU. SAFE GUARD THE SECURITY OF YOUR PASSWORD.

```
NEW PIN #  
0000
```

- After the four digit PIN has been entered, the display prompts you to confirm the new number:

CONFIRM CHANGE? YES

Press [ENTER] to accept the pin number and go to step 8.

- If the pin number is not correct or you don't want the selected security level, press [UP] to change the display to {CONFIRM CHANGE? / NO}

CONFIRM CHANGE? NO

Press [ENTER] to reject the security changes.

- The menu display returns to {-MENU- / SECURITY} screen.



REMEMBERING THE PIN # YOU SET, IS PROBABLY ONE OF THE MOST IMPORTANT FUNCTIONS OF SETTING SECURITY.

7.2.16 Number Format

The meaning of the comma and decimal point can be interchanged in the number format menu. You can also change the number of significant decimal places.



REFER TO THE TABLE IN SECTION 10: FACTORY DEFAULTS FOR FACTORY DECIMAL POSITION SETTINGS.



NUMBER FORMAT SETUP PROCEDURE

- Press [MENU]. Press [UP] or [DOWN] until the display reads {-MENU- / NUMBER FORMAT}. Press [ENTER] to continue into the number format sub-menu.
- The display shows the English numerical format of 9,999.99. Press [UP] to change to the European format of 9.999,99.

E.G.: 9,999.99 DECIMAL OR COMMA	Press [UP]	E.G.: 9.999,99 DECIMAL OR COMMA
------------------------------------	------------	------------------------------------

Press [ENTER] to accept the displayed format.

- The decimal position screen is displayed. Press [DOWN] to move the decimal position one place to the left. Press [UP] to move the decimal position one place to the right. For example, the screen displays 9.99999, pressing [DOWN] causes the display to change to 0.999999. The valid range is 999.999 to 0.0999999. When the decimal position satisfies your needs press [ENTER] to accept.

E.G.: 9.99999 DECIMAL POSITION	Press (DOWN)	E.G.: 0.999999 DECIMAL POSITION
-----------------------------------	--------------	------------------------------------

- The display returns to {-MENU- / DECIMAL FORMAT} screen.



PERFORM A PUMP FLOW CALIBRATION AFTER CHANGING THE DECIMAL POSITION.

7.2.17 Contrast Adjust

The DLC display contrast can be adjusted to a desired setting.



CONTRAST ADJUSTMENT PROCEDURE

1. Press [MENU]. Press [UP] or [DOWN] until the display reads {-MENU- / CONTRAST ADJUST}. Press [ENTER] to continue in the contrast adjust sub-menu.

- MENU -
CONTRAST ADJUST

2. Press and hold [UP] to darken the characters on the display. Press and hold [DOWN] to lighten the characters.

USE ARROWS TO
ADJUST CONTRAST



NOTE

BY GOING TOO FAR IN EITHER DIRECTION THE SCREEN CAN BE EXTREMELY DIFFICULT TO READ. PRESS AND HOLD THE OPPOSITE ARROW TO CORRECT THE DISPLAY OR YOU CAN RETURN TO THE FACTORY SETTING BY PRESSING [UP] AND [DOWN] SIMULTANEOUSLY WHILE IN THIS MENU.

3. Press [ENTER] to accept the desired contrast setting.
4. The display returns to {-MENU- / CONTRAST ADJUST} screen.



TIP

YOU CAN ADJUST THE CONTRAST AT ANY TIME BY PRESSING AND HOLDING [MENU] AND [UP] OR [DOWN] SIMULTANEOUSLY.

7.2.18 Serial Communications

Use {-MENU- / SERIAL COMM} to configure the serial communications port for operation using the MODBUS protocol (refer to **Section 14: Pulsanet Specification** section at the back of this manual for further information).

By using the serial communications port you can communicate digitally with your DLC. This allows a PC/PLC or another DLC or DLC to send and receive exact values. This eliminates inaccuracies typically associated with analog signal conversion.

In order for two or more devices to communicate using serial communications they must:

- Be electrically connected (refer to Section 5: Instrumentation, Electrical Wiring)
- Enabled
- Speak the same language (protocol)
- Speak at the same speed (baud rate)
- Use the same error detection protocol
- Have unique addressing in the network
- Have only one master on a given network

The {SERIAL COMM} menu allows the setting of these communication parameters.

If you are installing this DLC into an existing network, retrieve the following parameters (**bold** indicates default DLC values not network defaults).

COMMUNICATION PARAMETERS WORKSHEET								
MODBUS Type	<input checked="" type="checkbox"/> RTU	<input type="checkbox"/> ASCII						
Baud Rate	<input type="checkbox"/> 300	<input type="checkbox"/> 600	<input type="checkbox"/> 1200	<input type="checkbox"/> 2400	<input type="checkbox"/> 4800	<input checked="" type="checkbox"/> 9600	<input type="checkbox"/> 19,200	<input type="checkbox"/> 38,400
Data Parity	<input checked="" type="checkbox"/> Even	<input type="checkbox"/> Odd	<input type="checkbox"/> None					
Slave Address (Mark one or more)	<input checked="" type="checkbox"/> 1	<input type="checkbox"/> 2	<input type="checkbox"/> 3	<input type="checkbox"/> 4	<input type="checkbox"/> 5	<input type="checkbox"/> 6	<input type="checkbox"/> 7	<input type="checkbox"/> 8
	<input type="checkbox"/> 9	<input type="checkbox"/> 10	<input type="checkbox"/> 11	<input type="checkbox"/> 12	<input type="checkbox"/> 13	<input type="checkbox"/> 14	<input type="checkbox"/> 15	<input type="checkbox"/> 16
	<input type="checkbox"/> 17	<input type="checkbox"/> 18	<input type="checkbox"/> 19	<input type="checkbox"/> 20	<input type="checkbox"/> 21	<input type="checkbox"/> 22	<input type="checkbox"/> 23	<input type="checkbox"/> 24
	<input type="checkbox"/> 25	<input type="checkbox"/> 26	<input type="checkbox"/> 27	<input type="checkbox"/> 28	<input type="checkbox"/> 29	<input type="checkbox"/> 30	<input type="checkbox"/> 31	<input type="checkbox"/> 32



TIP

COMMUNICATIONS SETTINGS FOR DLC'S OPERATING IN A MULTIPLEXED ENVIRONMENT (I.E., ONE MOTOR DRIVING ONE OR MORE PUMP HEADS) ARE PRE-CONFIGURED.



COMMUNICATIONS SETUP PROCEDURE

- To access the Serial Communications menu press [MENU] and then press [UP] or [DOWN] until the {-MENU- / SERIAL COMM} screen is displayed.

```

- MENU -
SERIAL COMM
    
```

Press [ENTER] to view/modify the settings.

- The display prompts you to enable or disable the DLC's communications function.

```

SERIAL COMM          Press          SERIAL COMM
DISABLED              [UP]          ENABLED
    
```

Press [UP] or [DOWN] to reveal your selection. Press [ENTER] to accept your setting.

- The display prompts you for the type of communications. The DLC supports the standard MODBUS protocol. This standard defines two ways for devices to format the data they exchange:

- “RTU” is a binary format that offers improved data throughput.
- “ASCII” is a format based on the ANSI character standard. It has larger message blocks that yield reduced data throughput.

If you are installing a DLC into an existing network, you must match the setting you marked on the worksheet.

If this is a new **DLC/DLC only** installation, choose “RTU”. Press [UP] or [DOWN] to select your choice.

```

TYPE          Press          TYPE
RTU           [UP]          ASCII
    
```

Press [ENTER] to accept.

- The display prompts you to set the baud rate. The baud rate must be common for the network (i.e., all devices must be set at the same baud rate).

Set this value to that recorded on your worksheet previously or use the default setting of 9600.

BAUD RATE 9600

Press [UP] or [DOWN] to select your choice. Press [ENTER] to accept.

- The data parity display instructs the DLC on the use of the parity bit for error checking transferred data. This setting must match that of the existing network (refer to the selection you made on the work sheet). Otherwise, select the default value of **EVEN**.

DATA PARITY EVEN	Press [UP]	DATA PARITY ODD	Press [UP]	DATA PARITY NONE
---------------------	---------------	--------------------	---------------	---------------------

Press [UP] or [DOWN] to set the parity type.

- The Class setting defines how the DLC will operate in the network. If **Class** is set to **Master**, then the DLC tells other equipment (e.g., other DLC's) that are configured as slaves what to do (e.g., adjust stroke percent to 50%). If the Class setting is set for **Slave**, then the DLC is expecting a command from a **Master** unit.



YOU CAN ONLY HAVE ONE MASTER IN A NETWORK. THUS, THE CLASS SETTING WILL TYPICALLY BE SLAVE.

Press [UP] or [DOWN] to set the Class setting.

CLASS SLAVE	Press [UP]	CLASS MASTER
----------------	---------------	-----------------

Press [ENTER] to accept your setting.



THE MASTER DOES NOT HAVE A NETWORK ADDRESS. SKIP TO STEP 8.

- Every slave attached to a MODBUS network must have a unique address. Use the {NET ADDRESS} menu to set the address for this DLC.

If this is a new installation, check your worksheet for an available address.

NET ADDRESS 1

Press [UP] or [DOWN] to set the address. Press [ENTER] to accept your setting.

- If you selected **Master** in step 6, you must also set the amount of time the DLC should wait for a response from a **Slave**. If the **Slave** fails to respond within this time period, the **Master** will attempt to communicate with the next **Slave** on its list.

RESPONSE TIME 1.5 SECONDS

Press [UP] or [DOWN] to set the response time value (refer to the beginning of this section for tips on making this setting).

- If you selected **Master** in step 6, then you will be presented with a menu that allows you to identify **Slaves**. Otherwise go to step 10.

You can use the {IDENTIFY SLAVES} menu in one of two ways:

1. Set the **Slave** addresses manually
2. Use the **Auto Detect** feature

To use the **Auto Detect** feature, press [UP] or [DOWN] to change the setting to **Auto Detect**. Press [ENTER] to accept your selection.

```
IDENTIFY SLAVES
AUTO DETECT
```

The DLC will then display a status screen as it scans the 32 addresses for slave devices. The address under test is indicated to the right of **AUTO DETECT**.

```
PLEASE WAIT
AUTO DETECT #
```



YOU CAN USE THE AUTO DETECT FEATURE TO VALIDATE COMMUNICATIONS BETWEEN A MASTER DLC AND ONE OR MORE SLAVES. YOU CAN ALSO USE THE SERIAL DIAGNOSTIC MENU (REFER TO THE NEXT SECTION).

10. After the AUTO DETECT completes, you are returned to the {-MENU- / SERIAL COMM} screen. Repeat steps 1 through 9 without selecting AUTO DETECT to return to this menu.

7.2.19 Serial Diagnostics

The Serial Diagnostics menus are designed to assist you in the troubleshooting of the communications system.



SERIAL DIAGNOSTIC PROCEDURE

1. To access the Serial Diagnostics menu press [UP] or [DOWN] until the {-MENU- / SERIAL DIAG.} is displayed.

```
-MENU-
SERIAL DIAG
```

Press [ENTER].

2. The first menu shows the number of MODBUS messages exchanged by this node while the menu is displayed.

```
RECEIVE: 640
TRANSMIT: 640
```

3. Press either [UP] or [DOWN] to reset the count value. Press [ENTER] to proceed to the next screen.

```
LOOPBACK TEST
NO
```

- Or -

```
LOOPBACK TEST
YES
```

Selecting {YES} will start the test (skip to Step 6), or if {NO} is selected you are sent to the {ECHO TEST / NO} screen.

4. The {ECHO TEST / NO} screen is displayed.

```
ECHO TEST
NO
```

The Echo test causes the DLC to echo back all characters it received, much like the Loopback Device. You can then use another piece of equipment (e.g., PC) to originate characters.

- Press [ENTER] to skip the echo test or press [UP] and then [ENTER] to set {ECHO TEST / NO} to {ECHO TEST / YES} and initiate the test. The following screen is displayed:

```

ECHO CHARACTERS
TEST IN PROGRESS

```

When the Echo Test is complete, the following screen is displayed:

```

GOOD      XXXX
BAD       XXXX

```

- Press [ENTER] to exit the Echo Test and return to the {-MENU- / SERIAL COMM} screen.



Loopback Test Procedure

- The Loopback test is helpful in the identification of wiring errors and the possible need for line terminators at the ends of the network. While this menu is displayed the DLC transmits and expects to receive characters back. The display shows the percent (%) of successful characters exchanged.

The Loopback test requires the installation of a Loopback device at the end of the cable segment under test. This can be constructed according to

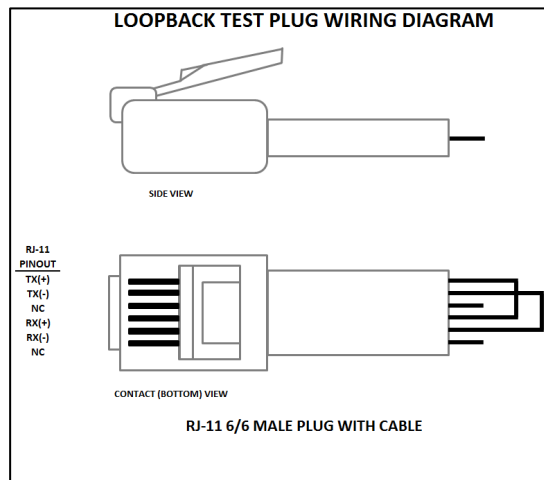

Figure 20 below:

Figure 20 – Loopback Device Wiring Diagram

- Install the cable under test in the second port. (J7 or J8)
- Install the loop back device at the far end of the cable under test.

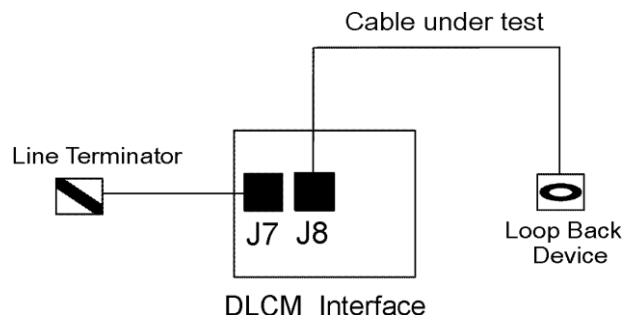

Figure 20.1 – Loop Back Circuit (Line Terminator Optional)

10. With the {LOOPBACK TEST YES} screen displayed, press [ENTER].

```
LOOPBACK TEST
YES
```

11. While the LOOPBACK test is being conducted, the following screen is displayed:

```
PLEASE WAIT
TEST IN PROGRESS
```

When the test is completed, a result screen is displayed:

```
100.0% SUCCESS
RETRY? YES
```

12. If the indicated percent of success is 100%, the cable segment is good and no further action is required. Skip to the end of this procedure.
13. If the indicated percent of success is less than 100% then double check the connections. Repeat the test by pressing [ENTER]. Refer to Section 8: Installation/Component for further details wiring details.
14. If the indicated percent of success persists network termination at the far ends of the network may be required. Install the line terminator in one port of the DLC in J7 or J8.

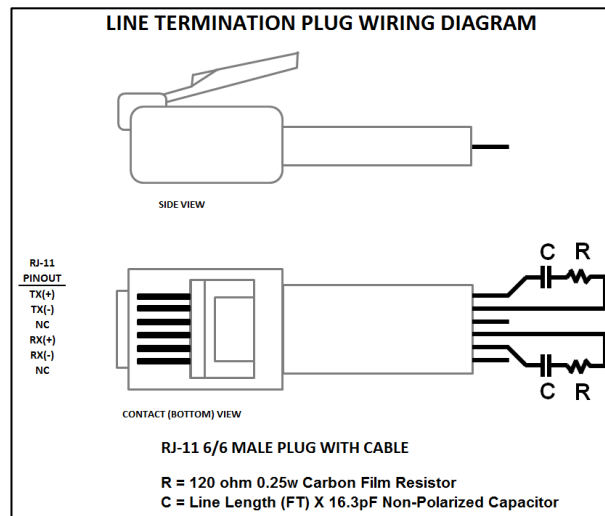

Figure 20.2 - Line Terminator

Alternatively, it may be possible to lower the baud rate on the network or use an ASCII message format instead of the RTU default. See Section 7: General Operations, Menu, Serial Communications for further details.

15. To exit the diagnostic menu press [UP] and then press [ENTER]. The {-MENU- / SERIAL COMM} screen is displayed.

7.2.20 Language

All displayed text can be displayed in English, Spanish, French or German.



LANGUAGE SETUP PROCEDURE

1. Press [MENU]. Press [UP] or [DOWN] until {-MENU- / LANGUAGE} is displayed.

```
- MENU -  
LANGUAGE
```

Press [ENTER] to continue through the language sub-menu.

2. The language type appears on the display. Press [UP] to scroll through the available languages.

```
LANGUAGE TYPE  
ENGLISH
```

Press
[UP]

```
LANGUAGE TYPE  
FRANCAIS
```

Press
[UP]

```
LANGUAGE TYPE  
DEUTSCH
```

Press
[UP]

```
LANGUAGE TYPE  
ESPANOL
```

When the correct language is displayed, press [ENTER] to activate. All text will be displayed in the selected language.

3. The display returns to {-MENU- / LANGUAGE}.

7.2.21 Factory Defaults Reset Procedure

All of the DLC settings can be returned to factory defaults.



FACTORY DEFAULTS RESET PROCEDURE

1. Press [MENU], then [UP] or [DOWN] until the {-MENU- / FACTORY DEFAULTS} screen is displayed.

```
- MENU -  
FACTORY DEFAULTS
```

Press [ENTER] to continue through the factory defaults sub-menu.

2. The display prompts you to not reset all the settings to the factory defaults.

```
FACTORY RESET?  
NO
```

If a Factory Reset is not desired, press [ENTER] to go back to the {-MENU- / FACTORY DEFAULTS} screen.

3. If the DLC is to be reset to the factory defaults, press [UP] to scroll the value to {YES}.

```
FACTORY RESET?  
YES
```

Press [ENTER] to accept your selection.

- The display prompts you to verify your action.



RESETTING FACTORY DEFAULTS WILL DESTROY ALL USER CALIBRATION INFORMATION.

ARE YOU SURE?
NO

Press [UP] to change the value to {YES}. Press [ENTER] to accept your selection. The following message is displayed:

PLEASE WAIT

- The first screen displayed during the Re-Set procedure prompts you to turn the motor on.

TURN MOTOR ON
TESTING ENCODER

- Press [MOTOR]. You will hear the pump motor spin up, and the DLC will perform an Encoder test (displaying the following message):

PLEASE WAIT
TESTING ENCODER

- When the Encoder test is complete, (usually takes about 2 or 3 seconds) the DLC performs a Zero Calibration (displaying the following message):

PLEASE WAIT
CALIBRATING ZERO

- When the Zero Calibration is complete, you are returned to the {-MENU- / FACTORY DEFAULTS} screen.
- Press [MENU] and the next screen displayed is:

MOTOR STOPPED

- Re-establish any Menu and Calibration settings that are non-standard at this time.

7.3 Units

By pressing [UNITS] with the motor on, the display will scroll through the CMH, GPH, LPH, CCH, CMM, GPM, LPM, CCM, % flow, or % stroke length. The DLC will automatically convert the stroke settings based on the calibrated flow, to the above referenced units.

The accuracy of the flow rate display is dependent on the pump flow calibration accuracy.

7.4 Varying the Flow Rate - Manually

When the DLC is in Manual Mode, pump flow rate can be increased by pressing [UP]. The flow rate is decreased by pressing [DOWN]. The DLC will display the

corresponding value of the flow adjustment.

If you attempt to adjust the DLC's hand-wheel while it is under power, the DLC will re-adjust back to the position specified by its programming. The hand-wheel is for emergency manual override only. Refer to **Section 13: General Repairs, Emergency Manual Pulsar Operation**.



DO NOT ADJUST THE DLC'S HAND-WHEEL WHILE THE POWER IS OFF. THIS WILL CAUSE THE DLC TO LOSE ITS ZERO POINT AND FORCE A {ZERO CALIBRATION} AT STARTUP.

7.5 Mode

Pressing [MODE], switches the DLC's operating mode. If the ANALOG MODE is set to ACTIVE, then pressing [MODE] will switch between {MANUAL MODE} and {ANALOG MODE}. When MODBUS MODE is set to ACTIVE, pressing [MODE] will switch between {MANUAL MODE} and {MODBUS MODE}. In essence, this key acts like a local auto/manual switch.

7.6 Batch

The DLC is capable of following up to three (3) different batch programs. The batches operate in two modes: One Time Only and Repeating.



WHEN DAYLIGHT SAVINGS IS SET TO AUTO CHANGE, USE CAUTION WHEN SETTING UP BATCHES THAT RUN THROUGH OR START OR STOP IN THE TIME CHANGE OVER PERIODS WHERE ONE FULL HOUR EITHER DOESN'T EXIST AT ALL OR OCCURS TWICE CONSECUTIVELY. IF YOU ARE IN DOUBT, SET THE {DAYLIGHT SAVINGS} OPTION TO [NO]. (REFER TO SECTION 7: GENERAL OPERATION, SET TIME AND DATE)

7.6.1 One-Time Only

The One Time Only batch will start at a specified time and run for a specified duration at a specified flow rate that you define (refer to **Figure 21**).

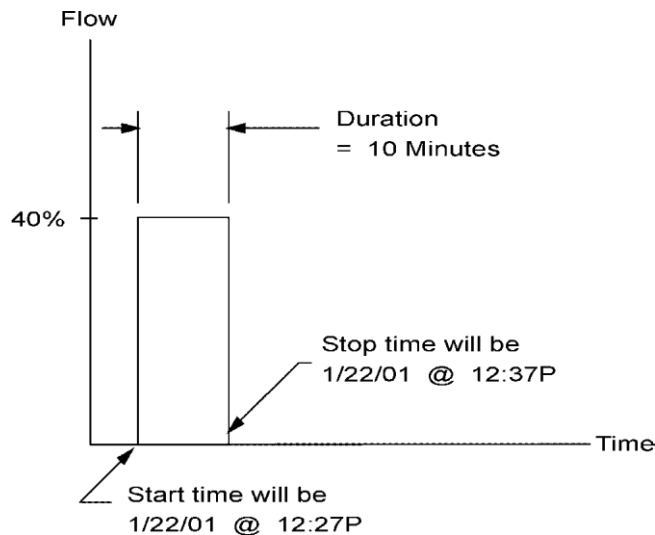

Figure 21 – One Time Only Batch

7.6.2 Repeating

A Repeating Batch will start at a specified time and run for a specified duration. It will stop for a specified period of time and then repeat the run time. This will continue indefinitely (refer to **Figure 22**).



ANY OF THE THREE BATCHES CAN BE SPECIFIED AS ONE TIME ONLY OR REPEATING.

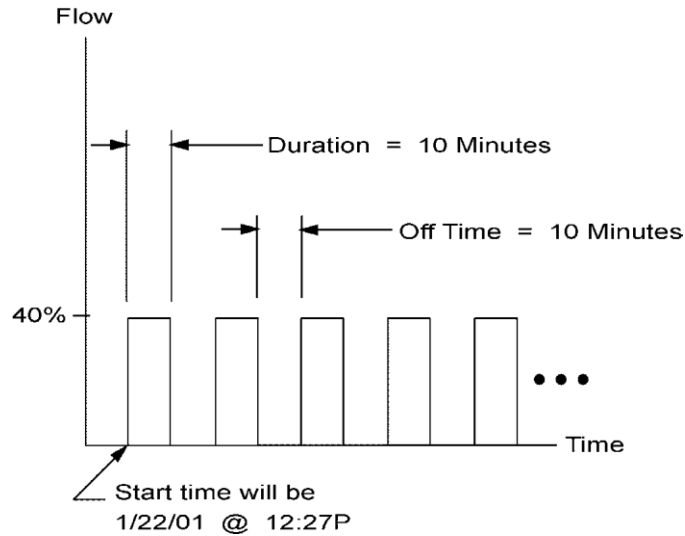

Figure 22 - Repeating Batch.

7.6.3 Overlapped

The batches can also be overlapped (refer to **Figure 23** below).

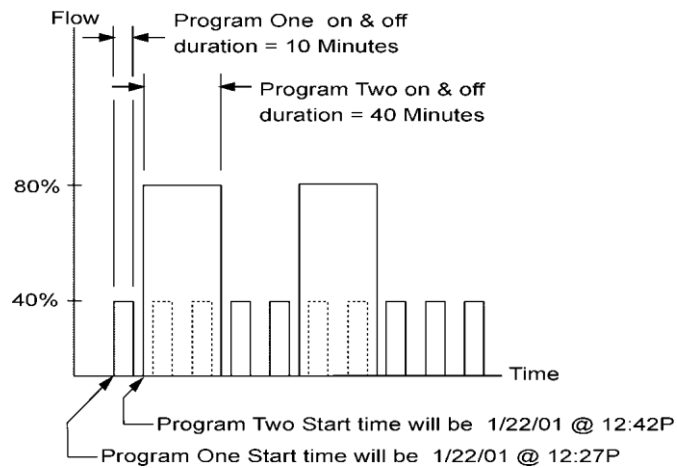

Figure 23 - Overlapping Batch.



WHEN THE BATCHES ARE OVERLAPPED, THE FLOW RATES ARE NOT ADDITIVE. THE HIGHEST OF THE TWO OR THREE FLOW RATES IS USED.

THE DLC CAN MAKE A 1% PER SECOND ADJUSTMENT OF PUMP STROKE LENGTH. REMEMBER THAT WHEN A BATCH STARTS, THE DLC WILL REQUIRE SOME AMOUNT OF TIME TO ACHIEVE THE NEW STROKE SETTING. THE ADJUSTMENT TIME IS TAKEN AS A PORTION OF THE BATCH RUNNING TIME. THIS WILL CAUSE THE OUTPUT OF THE PUMP TO BE SKEWED.



BATCHING SYSTEM SETUP PROCEDURE

1. Press [BATCH], to enter the batch setup menu.
2. The display will come up as {BATCHES / ACTIVE} or {BATCHES / INACTIVE}. Press [UP] to change the batch system to {ACTIVE}.



SETTING THE BATCH SYSTEM TO ACTIVE WILL CAUSE ANY PRE-CONFIGURED BATCHES THAT ARE SCHEDULED TO START AT THIS TIME, TO START IMMEDIATELY, SO YOU MIGHT WANT TO DO THIS LAST.

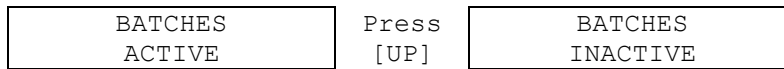

Press [ENTER] to continue on to the batch sub-menu.

3. The display shows {EDIT / BATCH #1}. Press [UP] to {EDIT / BATCH #2} and [UP] again to {EDIT / BATCH #3}.



The DLC is supplied with three user programmable batches. Press [ENTER] to select the desired batch to edit.

4. The display shows {BATCH #1 RATE / 92.5%} (the value and unit of flow will depend on previous programming). The {RATE} text will be flashing. You can press [UP] or [DOWN] to view/change the other menu items related to this batch (e.g., RATE / DURATION / TYPE / START, etc.). Pressing [ENTER] causes the {RATE} value to stop flashing and allows you to program the batch flow rate. Press [UP] or [DOWN] to set the value.



IF A VALUE HAS BEEN SET PREVIOUSLY IT WILL BE USED AS A STARTING POINT FOR THE NEW SETTING.



YOU CAN CHANGE THE DISPLAY UNITS AT ANY TIME BY PRESSING [UNITS].

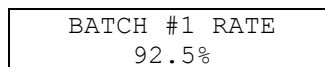

Press [ENTER] to accept your setting.

5. The display shows {BATCH #1 DURATION / XX HRS, XX MIN} with the word DURATION flashing. Press [ENTER] to set the duration (i.e., pump on time) of the batch.

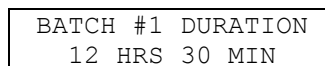

6. The hours value should now be flashing on the display. A line (cursor) under the second digit indicates the field to be changed. Press [UP] or [DOWN] to scroll through the numbers 0-99. Press [ENTER] to accept the desired hour setting.

```
BATCH #1 DURATION
 12 HRS 30 MIN
```

7. The cursor then moves to minutes field. Use [UP] or [DOWN] to scroll through the numbers 0-5. Set the first digit of the minute value one position at a time and press [ENTER] to accept it.

```
BATCH #1 DURATION
 12 HRS 30 MIN
```

8. The cursor then moves to the second digit of the minutes field. Use [UP] or [DOWN] to scroll through the numbers 0-9. Set the second digit of the minute value. Press [ENTER] to accept the desired second digit of the minute setting which completes the batch duration entry and exits the Batch duration screen.

```
BATCH #1 DURATION
 12 HRS 30 MIN
```

9. The display shows {BATCH #1 TYPE / ONE TIME ONLY}. Press [ENTER] to program the type of batch.

```
BATCH #1 TYPE
ONE TIME ONLY
```

10. You can select from one of two types of batches: either a one-time only batch or a repeating batch. A one-time only batch executes the batch only once. A repeating batch repeats an on/off cycle indefinitely. Press [UP] to scroll between the different batch types.

```
BATCH #1 TYPE   Press   BATCH #1 TYPE
ONE TIME ONLY   [UP]   REPEATING
```

Press [ENTER] to select the type of batch desired. If you select {ONE TIME ONLY} skip to step 12.

11. If a Repeating batch is selected, the display prompts you to enter the off duration time of the batch.

```
BATCH #1 OFF TIME
 10 HRS 23 MIN
```

12. The display shows {BATCH #1 START TIME / XX:XX XX/XX/XX}. Press [ENTER] to edit the batch start time. Press [UP] or [DOWN] to set the time and date value one character at a time. Press [ENTER] to accept your setting.

```
BATCH #1 START
 8:01 A  2/3/01
```

13. The display shows {BATCH #1 CONFIRM? / YES}. Press [ENTER] to confirm the batch or press [UP] to scroll to the {NO} value and then press [ENTER] to disregard the changes to the batch.

```
BATCH #1 CONFIRM?
      YES
```

Follow the procedure outlined in steps 3 through 13 for the Remaining Batches if desired.

14. If the batch was made active, the display changes to let you know the batch is now pending and displays the time and date the batch will begin.

BATCH #1 PENDING 8:01A 2/3/01

15. When the clock reaches the start time and date for the batch, the display automatically changes to indicate that the batch is running. The pump will then operate at the specified rate, for the specified time.



YOU CAN PRESS [UNITS] TO CHANGE THE DISPLAYED UNITS WHILE THE BATCH IS RUNNING.

BATCH #1 RUNNING 92.5%

While a batch is running you can display the time left in HH:MM:SS format by pressing either [UP], [DOWN] or [ENTER].

BATCH #1 RUNNING REMAIN 11:59:58

16. When the batch has operated for the specified time period, it will automatically shut off the pump's motor.
17. If this a One Time Only batch, the display will show the batch completed message and the operating mode will be set to manual.

BATCH #1 COMPLETED PRESS ANY KEY

Press any key to clear the display.

MOTOR OFF

18. If this was a repeating batch, the display will return to {BATCH #X PENDING / HH:MM MM/DD/YY} and the DLC will wait until its internal clock matches the displayed Time/Date. At that time, the batch will recycle.

BATCH #1 PENDING 6:45A 2/4/01

7.6.4 Inactivating the Batches

If the batch operation is not required to operate over a certain period of time, for instance the weekend, the batches should be inactivated.



BATCH INACTIVATION

Press [BATCH]. The screen will show the batch status: {BATCHES / ACTIVE}. Press [UP] to change the display to {BATCH / INACTIVE}. Press [BATCH] to accept and inactivate the batches and return to Manual Mode.

8 Diagrams: Installation / Component

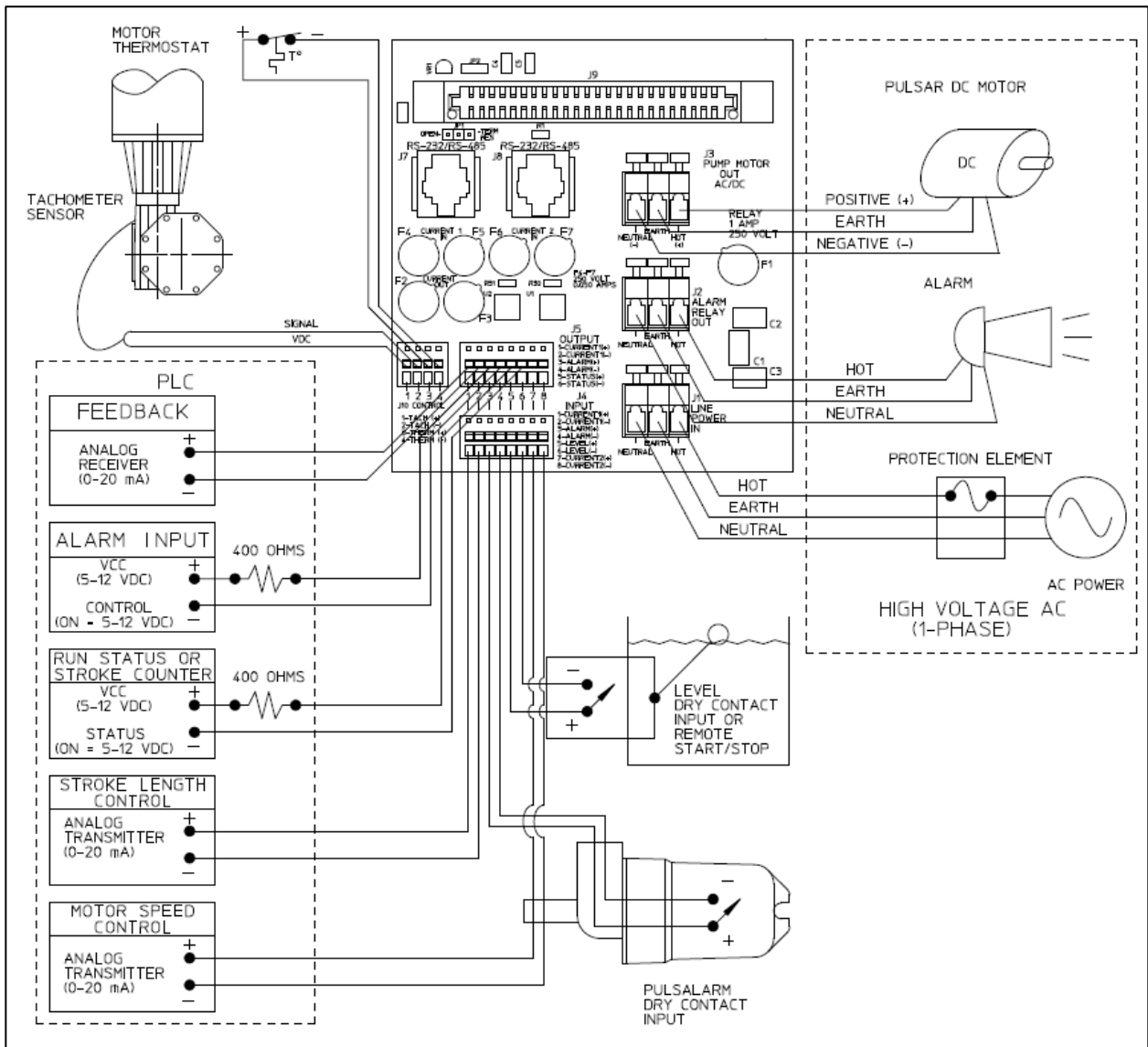

DIAGRAM 1 – DLC Wiring Diagram

Serial Communications - RS 485 Connections

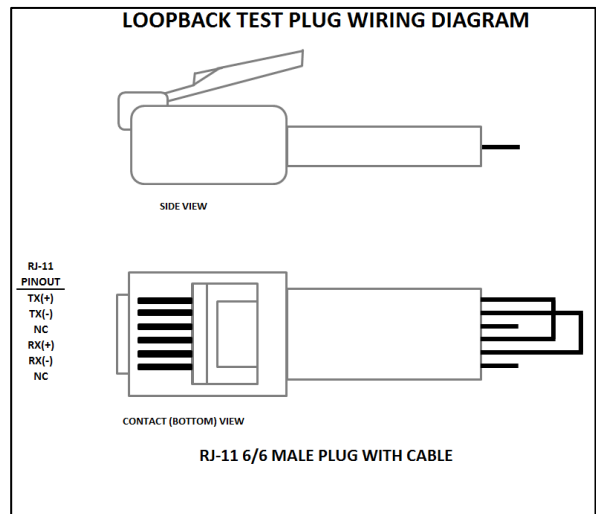
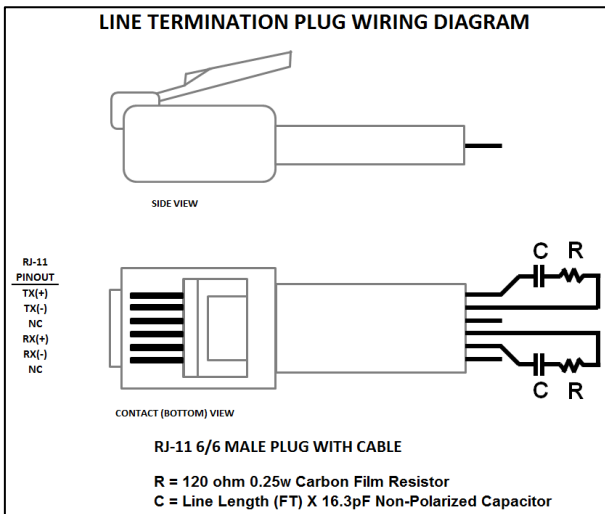
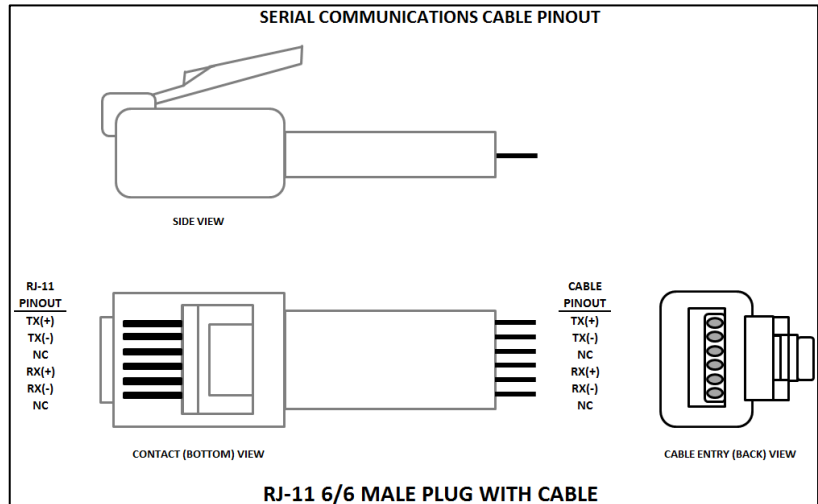
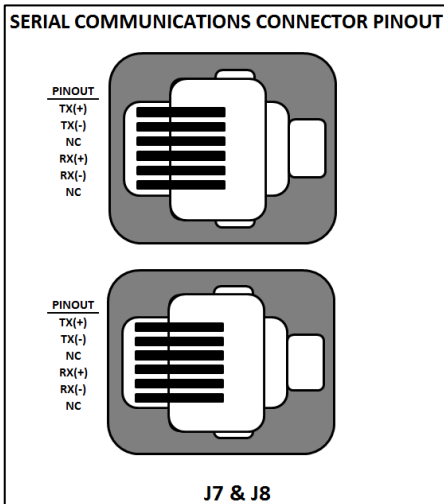
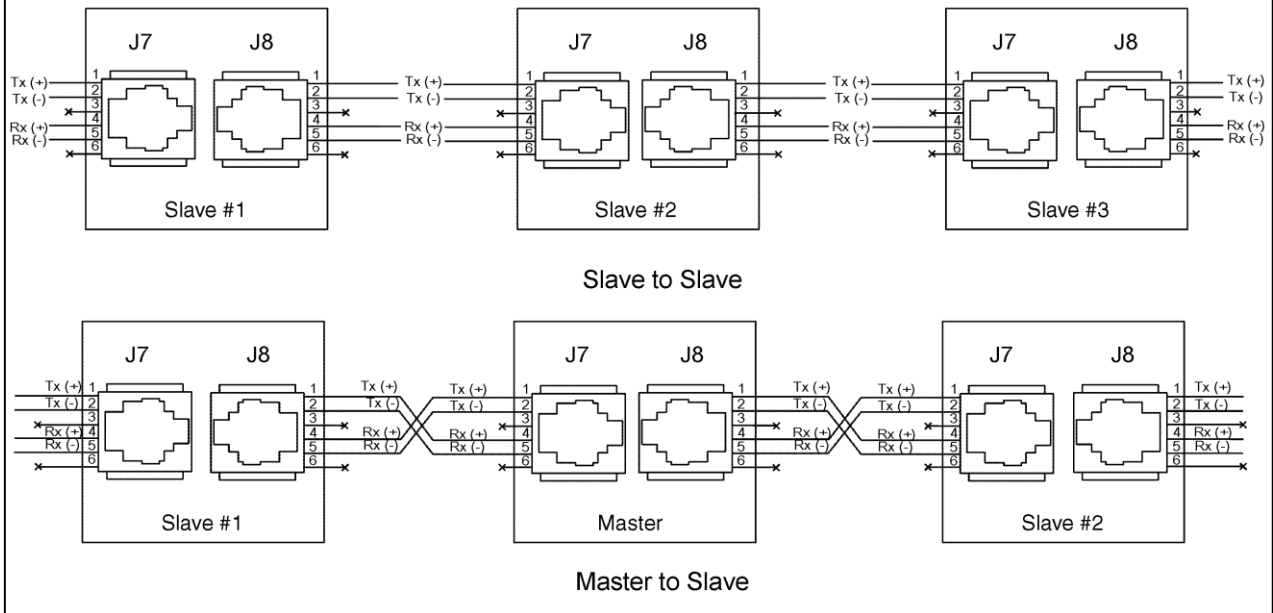

Diagram 2 – Serial Communications – RS 485 Connections

9 Specifications

Overview

STROKE LENGTH CONTROL

0-100% control range (Software programmable, 0% – 100% factory default)

0.1% resolution

10:1 turndown for accuracy specification

CALIBRATED FLOW

6 significant digits for displayed units of flow

PUMP ACCURACY

Accuracy	Standard Diaphragm	Diaphragm With Leak Detection	Single Solid Teflon Diaphragm	Capacity Reference	Turndown Range
					Stroke Length
Steady State	±0.5%	±0.5%	±0.5%	Set Point	10:1
Repeatability	±0.5%	±1.0%	±1.0%	Full Rating	10:1
Linearity	±1.0%	±3.0%	±3.0%	Full Rating	10:1

ADJUSTMENT RESPONSE

1% per second on stroke length

TEMPERATURE

–18°C to 40°C (0°F to 104°F) Operation

–18°C to 60°C (0°F to 140°F) Storage

LOW-VOLTAGE INPUTS

<i>Inputs</i>	<i>Field Wiring Location</i>	<i>Specification / Description</i>
Analog Input Channel 1	J4 Pin 1 is + J4 Pin 2 is –	Any signal within the range of 0 to 25mA (e.g.: 4-20) or 0 to 5 volts (e.g., 1-5v) Minimum span of 2mA or 0.4 volts. Note: No jumpers used. Displayed in mA. Split Ranging, Reverse Acting and Ratio Control standard on all units; accessible via calibration. Fused at 50mA. Protected against mis-wiring. Surge Protection: 7.4 Joules Isolation: 500 volts from all other inputs, outputs, and ground.

LOW-VOLTAGE INPUTS (continued)

Inputs	Field Wiring Location	Specification / Description
Analog Input Channel 2	J4 Pin 7 is + J4 Pin 8 is –	Specifications same as Channel 1. No function on DLC.
PULSAlarm (Leak Detection)	J4 Pin 3 is + J4 Pin 4 is –	Dry Contact. (Optically Isolated) – Do not apply powered signal. Isolation: Not isolated from Digital Input or Motor Thermostat, 500 volts from all other inputs, outputs and ground. May be software configured as Normally Open or Normally Closed. May be software configured to operate the Alarm Relay. May be configured to turn the Pump Motor off.
Digital Input Programmable as Level Input Or Remote Run / Stop	J4 Pin 5 is + J4 Pin 6 is –	Dry Contact. (Optically Isolated) – Do not apply powered signal. Isolation: Not isolated from PULSAlarm or Motor Thermostat, 500 volts from all other inputs, outputs and ground. May be software configured as Normally Open or Normally Closed. May be software configured to operate the Alarm Relay (Level Input Only). May be configured to turn the Pump Motor off. (Level Input Only)

LOW-VOLTAGE OUTPUTS

Outputs	Field Wiring Location	Specification / Description
Analog Output Channel	J5 Pin 1 is + J5 Pin 2 is –	Any signal within the range of 0 – 20mA (e.g.: 4-20). Minimum span of 2mA. Maximum load: 700 ohms. Reverse Acting standard on all units, which is accessible via calibration. Fused at 50mA protected against mis-wiring. Surge Protection: 7.4 Joules Isolation: 500 volts from all inputs and outputs.
Alarm Status	J5 Pin 3 is + J5 Pin 4 is –	Dry Contact (Transistor Type) VCE (SAT): 0.3 volts Max forward current: 50mA Maximum 32VDC On-state resistance: 100 ohms Isolation: 5000 volts from all inputs, outputs and ground. Follows the state of High-Voltage Alarm Output, which may be software configured as Normally Open or Normally Closed.

LOW-VOLTAGE OUTPUTS (continued)

Outputs	Field Wiring Location	Specification / Description
Digital Output Programmable as Remote Run Status Or Stroke Counter Or Mode Indication	J5 Pin 5 is + J5 Pin 6 is –	Dry Contact (Transistor Type) VCE (SAT): 0.3 volts Max forward current: 50mA Maximum 32VDC On-state resistance: 100 ohms Isolation: 5000 volts from all inputs, outputs and ground. May be software configured as Normally Open or Normally Closed. (Remote Run Status and Mode Indication only).

HIGH-VOLTAGE INPUTS

Inputs	Field Wiring Location	Specification / Description
Line Power:	J1	Factory configured to one of the following: 115VAC ±10%, 50/60 Hz, 10 Amp max 230VAC ±10%, 50/60 Hz, 5 Amp max Surge Protection: 7.4 Joules Software protected against Over/Under voltage (user selectable)

HIGH-VOLTAGE OUTPUTS

Inputs	Field Wiring Location	Specification / Description
Alarm Relay	J2	Fused at 1 amp at rated Line voltage. May be software configured as Normally Open or Normally Closed.
Pump Motor	J3	SCR Controlled Single Phase Induction Motor Output 50/60Hz, 8A Max at 115VAC 1750 RPM, NEMA 56C Frame, Class F or better insulation.

SERIAL COMMUNICATIONS

Inputs	Field Wiring Location	Specification / Description
RS-485	J7 & J8	Max Cable length: 1200 meters (4000 feet) Max Address sites: 32 See Section 8: Diagrams Installation/Component for further line termination when required. Isolation: 500 volts from ground and all other inputs and outputs.

CONTROL INPUTS

Control Inputs	Field Wiring Location	Specification / Description
Tachometer Sensor	J10 Pin 1 is VDC J10 Pin 2 is Tach	Connection point for Tach Sensor. Used for sensing Motor Speed. Not supplied on DLC Model.
Motor Thermostat	J10 Pin 3 is + J10 Pin 4 is -	Dry Contact (Optically Isolated) – Do not apply powered signal. Isolation: Not isolated from PULSAlarm or Digital Input, 500 volts from all other inputs, outputs, and ground. May be software configured as Normally Open or Normally Closed (default). May be software configured to operate the Alarm Relay (default is YES). May be software configured to turn the Pump Motor OFF (default). If MOTOR OFF is selected may optionally restart the Pump Motor when the thermostat resets (default).

10 Factory Default Values

CALIBRATION

Pump Flow	1-Point Calibration on PULSAR at Rated Flow and Pressure.
Analog Input	4.0 - 20.0mA @ 100% Ratio
Analog Output	4.0 - 20.0mA @ 100% Ratio

DIAGNOSTICS

Alarms	Cleared
--------	---------

DATE/TIME

Date Format	MM/DD/YY
Time Format	24:00
Daylight Savings Time	No

ANALOG INPUT	Enabled – Number of input channels enabled is one.
Failure Mode channel #1	Freeze at last signal / Restore to Analog Mode/ Error message enabled
Sample Average channel #1	20 Samples
Sample Update channel #1	20 Samples (5.0 Seconds)

ANALOG OUTPUT

Stroke setting	Calibrated Stroke
----------------	-------------------

END POINT & PRIORITY

Stroke Minimum	0%
Stroke Maximum	100%

LEAK DETECTION

Failure Mode	Inactive
--------------	----------

LEVEL INPUT

Failure Mode	Inactive
--------------	----------

DIGITAL OUTPUT

Run/Stop	Normally Open
----------	---------------

MOTOR THERMOSTAT

Input	Enabled
Switch	Normally Closed
Motor	Off
Alarm	On
Restore to	Motor On
OVER TEMPERATURE	
Error Message	Enabled
POWER FAILURE	
Failure Mode	During power up – Motor Off
Wrong Voltage	During power up – Motor Off
ALARM RELAY	
Relay Output	Normally Open
SECURITY	Remains as previously set
NUMBER FORMAT	
Separators	X , XXX . XX (Comma / Decimal)
Position	PULSAR dependent (e.g., 9.99999, 0.999999, etc.) Factory set to match pump head size. Refer to Factory Decimal Position Settings below.
CONTRAST	Restored to initial Factory setting
SERIAL COMM	
Net Address	Disabled
LANGUAGE	English
MODE	Manual – Motor Off
UNITS	Percent (%)
BATCH	Inactive
Batch #n Rate	0%
Batch #n Duration	0 H 00 M
Batch #n Type	One Time Only
Batch #n Start	Current Date and Time for first setting
FLOW RATE	0%
Stroke Position	0%

FACTORY DECIMAL POSITION SETTINGS

RATED CAPACITY RANGE		UNITS	-MENU- / DECIMAL POSITION	
5.99999	to 59.9999	cmh	999.999	
1,585.03	to 15,850.3	gph	999.999	
5,999.99	to 59,999.9	lph	999.999	
5,999,990	to 59,999,990	cch	999.999	
0.0999999	to 0.999999	cmm	999.999	
26.4172	to 246.172	gpm	999.999	
99.9999	to 999.999	lpm	999.999	
99,999.9	to 999,999	ccm	999.999	
<hr/>				
0.599999	to 5.99999	cmh	99.9999	
158.503	to 1,585.03	gph	99.9999	
599.999	to 5,999.99	lph	99.9999	
599,999	to 5,999,990	cch	99.9999	
0.00999999	to 0.0999999	cmm	99.9999	
2.64172	to 26.4172	gpm	99.9999	
9.99999	to 99.9999	lpm	99.9999	
9,999.99	to 99,999.9	ccm	99.9999	
<hr/>				
0.0599999	to 0.599999	cmh	9.99999 (default size)	Actual flow is usually slightly larger than the rated flow.
15.8503	to 158.503	gph	9.99999 (default size)	
59.9999	to 599.999	lph	9.99999 (default size)	
59,999.9	to 599,999	cch	9.99999 (default size)	
0.000999999	to 0.00999999	cmm	9.99999 (default size)	
0.264172	to 2.64172	gpm	9.99999 (default size)	
0.999999	to 9.99999	lpm	9.99999 (default size)	
999.999	to 9,999.99	ccm	9.99999 (default size)	
<hr/>				
0.00599999	to 0.0599999	chm	0.999999	
1.58503	to 15.8503	gph	0.999999	
5.99999	to 59.9999	lph	0.999999	
5,999.99	to 59,999.9	cch	0.999999	
0.0000999999	to 0.000999999	cmm	0.999999	
0.0264172	to 0.264172	gpm	0.999999	
0.0999999	to 0.999999	lpm	0.999999	
99.9999	to 999.999	ccm	0.999999	
<hr/>				
0.000000001	to 0.00599999	cmh	0.0999999	
0.000001	to 1.58503	gph	0.0999999	
0.000001	to 5.99999	lph	0.0999999	
0.001	to 5,999.99	cch	0.0999999	
0.00000000001	to 0.0000999999	cmm	0.0999999	
0.00000001	to 0.264172	gpm	0.0999999	
0.00000001	to 0.0999999	lpm	0.0999999	
0.00001	to 99.9999	ccm	0.0999999	

11 Troubleshooting Guide

11.1 System Diagnostics

Your DLC contains extensive diagnostics that allow it to determine the source of common problems. If your DLC is not operating properly, your first course of action should be to review the {DIAGNOSTICS} sub-menu. To access this menu from the standard operating mode follow this procedure (provided your user interface – keypad and display – is functioning):

1. Press [MOTOR] repeatedly until the display reads {MOTOR OFF}.
2. Cycle power to the DLC (turn the main OFF then ON). This will cause the self-test routine to re- execute.
3. Press [MENU]. The screen {-MENU- / DIAGNOSTICS-1} is displayed. The value, in this case '1' indicates how many failures were detected.
4. Press [ENTER] to enter the Diagnostics Menu. The screen {DIAG MENU 1/11 / POWER IN: OK} is displayed.
5. Repeatedly press [UP] to cycle through all nine Diagnostic screens.
6. If a screen displays a FAIL message, press [ENTER] to display the time and date the failure occurred. Press [ENTER] again to display the clear screen. Press [UP] and then [ENTER] to clear the message. (This paragraph does not apply should you encounter a Battery Fail or Circuit Fail situation).

Make a note of any failures reported in the Diagnostics Menu. Using this information, proceed with the troubleshooting instructions below:



OTHER ACTIONS MAY BE NECESSARY TO BRING THE PROCESS BACK TO NORMAL CONDITIONS BEFORE CLEARING A FAILURE.

MENU (DIAGNOSTICS)		
SYMPTOM	PROBABLE CAUSE	POSSIBLE SOLUTION
DIAG 1/11 POWER IN: FAIL	The power to the DLC failed while the pump motor was running.	Place DLC in {MOTOR OFF} operating mode before disconnection power. Refer to POWER Troubleshooting.
DIAG 2/11 ANALOG IN: FAIL	The Analog Input signal fail under the calibrated range, or fell to 0 within 0.25 seconds (i.e., the signal was changing by more than 8.8 mA per second and was less than 0.3 mA).	Place DLC in {MANUAL MODE} or OFF before the signal loss occurs. Recalibrate Analog Input. Condition Analog Input Signal. Refer to ANALOG INPUT troubleshooting.
DIAG 3/11 MODBUS FAIL	A properly formatted and addressed MODBUS message was not received in the allotted time.	Increase the Response Time setting.
DIAG 4/11 LEAK DETECTION: FAIL	The Leak-Detection Switch closure activated according to its configuration.	Diaphragm may have failed. Refer to Pump IOM or review Section 7: General Operation, Leak-Detection Failure Setup. Refer to PULSAlarm Leak- Detection Troubleshooting.

MENU (DIAGNOSTICS)		
SYMPTOM	PROBABLE CAUSE	POSSIBLE SOLUTION
DIAG 5/11 LEVEL INPUT: FAIL	The Level Input Switch closure activated according to its configuration.	If abnormal, review Section 7: General Operation, Level Input Failure Setup. Refer to LEVEL INPUT troubleshooting.
DIAG 6/11 MOTOR TEMP	The pump motor exceeded its maximum internal temperature.	Relocate to a cooler area and/or out of direct sunlight. Install secondary fan.
DIAG 7/11 DRIVE TEMP: FAIL	The DLC internal temperature has exceeded the rating.	Re-locate the DLC to an environment with lower ambient temperatures. Refer to Section 9: Specifications.
DIAG 8/11 BATTERY: FAIL	The DLC clock is backed by a Lithium Battery with a 10 year life.	The life expectancy is over. Contact Technical Service.
DIAG 9/11 CIRCUIT: FAIL *RAM*	The Random Access Memory (RAM) on the mother board cannot be reliably read and/or written to.	Cycle Power on unit to double check error. Contact Technical Services.
DIAG 9/11 CIRCUIT: FAIL *EEPROM*	The Electronically Erasable Programmable Read Only Memory (EEPROM) on the mother board cannot be read and/or written to.	Cycle Power on unit to double check error. Contact Technical Services.
DIAG 9/11 CIRCUIT: FAIL *MOTOR*	The DLC's internal motor failed to respond when given a command to do so.	Cycle Power on unit to double check error. Review MANUAL KNOB / DLC INTERNAL DRIVE MOTOR troubleshooting. Contact Technical Services.
	The DLC's internal motor has achieved its Duty Cycle limit: 50% over a 20 minute interval.	Cycle Power to clear. Reduce motor run time by changing batch or conditioning analog input or Averaging Parameters.
DISPLAY		
SYMPTOM	PROBABLE CAUSE	POSSIBLE SOLUTION
No display back-lighting	No power supplied	Check power source. Plug & Circuit Breaker
	Supply power wired incorrectly	Check wiring
	Supply power outside of specification	Check voltage/frequency against specification
	Low-voltage I/O wired incorrectly	Check wiring
	Display ribbon cable loose	Contact Technical Service
	Low-voltage power supply failed	Contact Technical Service
No display back-lighting	The DLC internal temperature has exceeded the rating.	Relocate the DLC to an environment with lower ambient temperatures. Refer to Section 9: Specifications.
No text on display	Contrast out of adjustment	Adjust with [MENU] + [UP] or [MENU] + [DOWN]
	Software did not initiate properly	Cycle power
	Memory corrupted	Cycle power. Perform Factory Re-initialize.
	Environment exceeds 40°C (104°F)	Relocate to another area

POWER		
SYMPTOM	PROBABLE CAUSE	POSSIBLE SOLUTION
No power indicators	No power supplied	Check power source. Plug & Circuit Breaker
	Supply power wired incorrectly	Check wiring
	Supply power outside of specification	Check voltage/frequency against specification
	Low-voltage I/O wired incorrectly	Check wiring
	Low-voltage power supply failed	Contact Technical Service

PULSAR MOTOR (1-Phase)		
SYMPTOM	PROBABLE CAUSE	POSSIBLE SOLUTION
Motor will not start	No power supplied	Check power source to DLC
	Motor wired incorrectly	Check wiring
	Supply power outside of specification	Check voltage/frequency against name plate
	Motor key not pressed.	Press [MOTOR] to start motor.
	Keypad problem (Motor key)	Refer to <i>Keypad Troubleshooting</i> section.
	Remote Motor Switch is off	Turn switch on
	Software did not initiate properly	Cycle power
	Alarm or Level input set with option MOTOR OFF? Set to YES.	Correct Alarm or Level condition. Set MOTOR OFF? To NO.
	PULSAR mechanicals locked	Check pump, reference PULSAR IOM.
	Motor Thermostat not connected or programmed	Connect or program the Motor Thermostat
	Solid-state relay failed	Contact Technical Service
	MODBUS in control	Check MODBUS Control Application
Motor will not stop	Motor wired incorrectly	Check wiring
	Software did not initiate properly	Cycle power
	Motor key not pressed.	Press [MOTOR] to stop motor.
	Keypad problem – Motor Key.	Refer to the Keypad Troubleshooting section
	Solid-state relay failed	Contact Technical Services

ALARM RELAY (High-Voltage J2)		
SYMPTOM	PROBABLE CAUSE	POSSIBLE SOLUTION
Alarm Relay will not activate	Relay wired incorrectly	Check wiring
	Relay fuse blown	Replace with 1A@250 VAC fuse
	Software not configured properly	Refer to Section 7: General Operation, Menu.

ANALOG INPUT		
SYMPTOM	PROBABLE CAUSE	POSSIBLE SOLUTION
Not responding to Analog (mA) Input	Input wired incorrectly	Check wiring
	Input not wired to correct channel	Refer to Section 5: Installation, Analog Input for wiring instructions.
	Input fuse(s) blown	Replace F4 & F5 w/ 50 mA@250 VAC for channel #1 and F6 & F7 for channel #2
	Not in Analog Operation Mode	Press [MODE] or configure Active. Refer to Section 7: General Operation, Analog Mode
	Input not calibrated properly	Review Section 7: General Operation, Analog Input Signal Calibration
Signal failure message displayed with no signal loss	Break in wiring	Check wiring
	Input outside of specification	Boost/Condition signal
	Process fluctuates too rapidly: less than 0.3 mA and changing by more than 8.8 mA/s	Condition signal. Change failure mode. Recalibrate.
Lo Analog Input point (e.g., 4.0 mA) does not equate to 0% unit reading	Miss-calibrated	Recalibrate
	0% calibration value misinterpreted	The "0% = 4.0 mA" calibration screen refers to 0% flow. Not 0% stroke.
	Jitters or slow response	Change averaging parameters. Refer to Section 7: General Operation, Analog Mode.

PULSAlarm (Leak Detection)		
SYMPTOM	PROBABLE CAUSE	POSSIBLE SOLUTION
Not responding to PULSAlarm Input	Relay wired incorrectly	Check wiring
	Input not configured properly	Review Section 7: General Operation: Menu, Leak-Detection Failure Setup
	Solid-state device used	Remove and replace with dry contact. If no change, contact Technical Service.

LEVEL		
SYMPTOM	PROBABLE CAUSE	POSSIBLE SOLUTION
Not responding to Level Input	Input wired incorrectly	Check wiring
	Input not configured properly	Review Section 7: General Operation: Menu, Level Input Failure Setup
	Solid-state device used	Remove and replace with dry contact. If no change, contact Technical Service.

ANALOG OUTPUT		
SYMPTOM	PROBABLE CAUSE	POSSIBLE SOLUTION
No Analog (mA) signal present	Output wired incorrectly	Check wiring
	Output fuse(s) blown	Replace F2 & F3 with 50 mA@250 VAC.
Not tracking	Output not calibrated properly	Review Section 7: General Operation: Analog Output Calibration

ALARM RELAY OUTPUT (Low-Voltage J5)		
SYMPTOM	PROBABLE CAUSE	POSSIBLE SOLUTION
No Output	Output wired incorrectly	Check wiring
	External device not powering output	Refer to Section 8: Diagram 1, DLC Wiring Diagram. External device must supply voltage to solid-state switch.
	Alarm options not set	Review Section 7: General Operation, Leak-Detection/Level-Input Setup/Alarm Relay.

MANUAL ADJUSTMENT KNOB/DLC INTERNAL DRIVE MOTOR		
SYMPTOM	PROBABLE CAUSE	POSSIBLE SOLUTION
Knob will not turn under DLC control. Display shows {DUTY CYCLE}	Internal DLC Synchronous motor has achieved its duty cycle limit of 50% ON time (based on a 20 minute interval). Rapidly cycling batches and wildly swinging analog inputs will cause this motor to run continuously.	Eliminate batches that are cycling too rapidly (e.g., changing stroke from 0 to 100% one minute and 100 to 0% the next – the internal drive motor runs all the time). Condition analog input signal. Cycle Power. Wait for 'cool-down' period. Refer to Section 5: Installation, High-Voltage Connections, PULSAR Motor.
Knob turns at power-up	Normal Zero Calibration. Display should read {PLEASE WAIT / CALIBRATING ZERO}	Do not turn knob by hand while DLC's power is off.

KEYPAD		
SYMPTOM	PROBABLE CAUSE	POSSIBLE SOLUTION
Display does not respond to keypad entry	Display contrast out of adjustment	Press and hold [MENU] and [UP]. See Display Troubleshooting.
	Software did not initiate properly	Cycle power
	Memory corrupted	Cycle power. Perform factory re-initialize.
	Keypad connector loose	Contact Technical Services

BATCH OPERATION		
SYMPTOM	PROBABLE CAUSE	POSSIBLE SOLUTION
Activated batch appears to be running through batches rapidly	Repeating Batch activated with Old Start Date. For example, today is 1/22/16, you have a repeating batch programmed to start on 1/5/16. The display will show the 'run-through' of all batches between the start day and time and today.	Change Batch start-time/date to current or future date/time.
Repeating Batch will not start	Batch duration is set to 0 hours and 0 minutes	Duration must be greater than 0 minutes for batch to activate.

CALIBRATION		
SYMPTOM	PROBABLE CAUSE	POSSIBLE SOLUTION
Message: {Terminated/Press any key} appears during Calibration	Manual Knob adjusted while Calibration session was active	Do not touch the Manual adjustment knob while a Calibration session is active. Press any key to clear message.

UNITS		
SYMPTOM	PROBABLE CAUSE	POSSIBLE SOLUTION
Units do not increment with change in %	Unit not properly calibrated. Calibration beyond display resolution.	Re-calibrate to value within display range. Change number format to give additional precision.
Displayed units read – 000000	High pressure pump. Due to compressibility, the pump will not discharge fluid until the Stroke Adjustment is above a non-zero value (e.g., set the adjustment to 3% and the pump discharges fluid. Set the adjustment below 3% and no fluid will be discharged). When the stroke is set below the zero point, the display shows -000000.	Display is normal. Increase the stroke setting until the unit reads properly. Re-calibrate if necessary.

SERIAL COMMUNICATIONS		
SYMPTOM	PROBABLE CAUSE	POSSIBLE SOLUTION
No response to Master	Wiring	Master / Slave wiring incorrect. Refer to Section 5: Installation, Serial Communications Input.
	Communications setting mismatch between Master & Slave	Check Communications Settings. Refer to Section 7: General Operation, Serial Communications.
	Master not receiving	Use serial diagnostics to check receipt and transmission of characters. Refer to Section 7.

SERIAL COMMUNICATIONS		
SYMPTOM	PROBABLE CAUSE	POSSIBLE SOLUTION
Poor performance	Wiring/interference	Use proper wire type. Limit total network length to 1200M (4000 ft) Do not run communication wire in the same conduit with the power wire. Avoid runs near large motors. Add Termination.
	Communication Settings	Refer to the guidelines in Section 7: General Operation: Serial Communications.
	Network (Length/Line Termination)	Remove all Termination.
		Reduce Network Length.
	Add AC End-of-Line Termination as defined in Section 8: Diagrams.	
Frequent message {MODBUS SIG. FAIL}	Time out setting	Refer to Section 7: General Operation, MODBUS Signal Failure Setup for guidelines on time out settings.

MISCELLANEOUS		
SYMPTOM	PROBABLE CAUSE	POSSIBLE SOLUTION
Over voltage or under voltage message displayed	Incoming Power un-reliable Note: you must power off and then power back up to clear	DLC should have separate branch circuit taken from main. Re-wire. Consider surge-suppression.
	DLC factory configured for operating voltage other than input	DLC must run under Factory configured operating voltage. Locate source of correct voltage and re-wire
Power failure message displayed	PULSAR motor running at time of power loss	Turn PULSAR motor off before powering DLC down.

ENCODER ERROR		
SYMPTOM	PROBABLE CAUSE	POSSIBLE SOLUTION
Message: {ENCODER ERROR/PRESS ENTER} displays during encoder test.	Encoder defective	Refer to Section 11: Troubleshooting, Encoder Diagnostics.
	Internal Motor unable to turn adjustment knob	Broken or jammed gears – refer to Section 11: Troubleshooting, Encoder Diagnostics.
		Defective motor – refer to Section 11: Troubleshooting, Encoder Diagnostics.
		Defective Drive circuits – refer to Section 11: Troubleshooting, Encoder Diagnostics.
		Defective encoder or wiring

11.2 Encoder Diagnostics

Pulsafeeder supplies the DLC electronic controllers on the PULSAR line of metering pumps. This controller utilizes a common drive system to actuate the stroke length mechanism within the pump. This drive system consists of a motor, gear train, and a digital encoder, which allows the

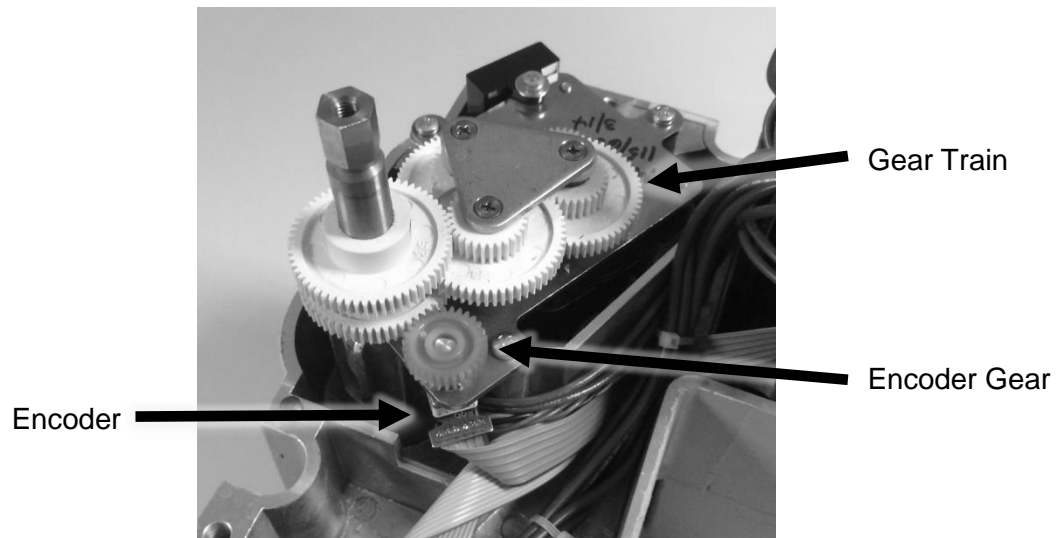

controller to track the position of the stroke mechanism. The encoder produces digital pulses as the adjustment shaft rotates. By tracking these pulses, the controller can adjust the stroke position with a very high level of accuracy.

Figure 24 – Encoder position within the enclosure

If, at any time during this process the DLC detects an error the following screen is displayed:

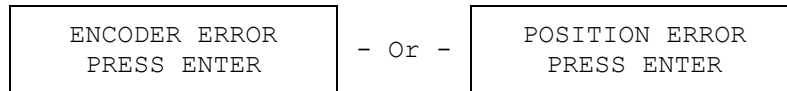

NOTE: THERE COULD BE INTERNAL DAMAGE TO THE ENCODER OR GEAR TRAIN – POSSIBLY AN OBSTRUCTION OR A BROKEN GEAR.

There can be a number of reasons for this failure; the following will guide you through several possibilities.

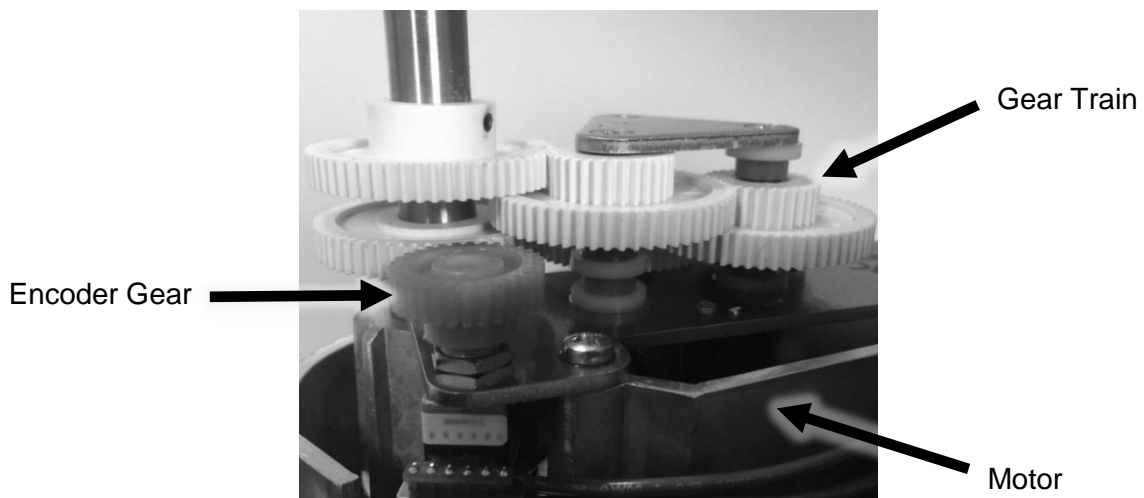

Figure 25 – Encoder and Gear Train layout

11.2.1 Troubleshooting

11.2.1.1 First Steps

1. Remove AC power from the controller.
2. Rotate the stroke adjustment knob several turns manually to increase the setting (Counter Clockwise). The knob can be turned 25 turns. The mechanism includes hard stops at 0% and 100% that prevent over rotation. Do not force the knob – try turning in the opposite direction.
3. Ensure that the knob rotates smoothly for several full revolutions in BOTH directions. Skip to step 5.
4. A majority of encoder issues with the DLC are associated with mis-alignment of the DLC's output coupling with the pumps stroke adjustment mechanism. To eliminate this condition, **loosen but do not remove the 4 screws that hold the controller to the top of the pump.** See Figure 26, Controller Pump Interface
5. Replace covers if necessary and re-apply power to the controller. Use [UP] or [DOWN] to cause the DLC to adjust the stroke setting.
6. If the cause of the error was a mechanical jam, it may be necessary to perform a Zero Calibration. See Section 6: Startup Instructions, Overview, Performing a Factory Reinitialization. If the cause was a mis-alignment issue, the control should start adjusting properly.
7. If the hold down screws were loosened in step 4, retighten evenly while the unit is adjusting.
8. Monitor the unit as necessary for further faults.

11.2.1.2 Mechanical Problem

A primary cause of encoder errors is a mechanical problem within the pump or the controller. In these cases, it may or may not be possible to rotate the knob as described above. Suggested troubleshooting sequence:

1. Remove the controller from the pump to separate the mechanisms.
2. Rotate the stroke adjustment mechanism in the pump and then the controller by hand to determine which part may not be functioning correctly.
3. If the trouble appears isolated to the pump, see 11.2.1.3 for further information.
4. If the trouble appears to be within the controller, see 11.2.1.4 for access to the interior of the controller.

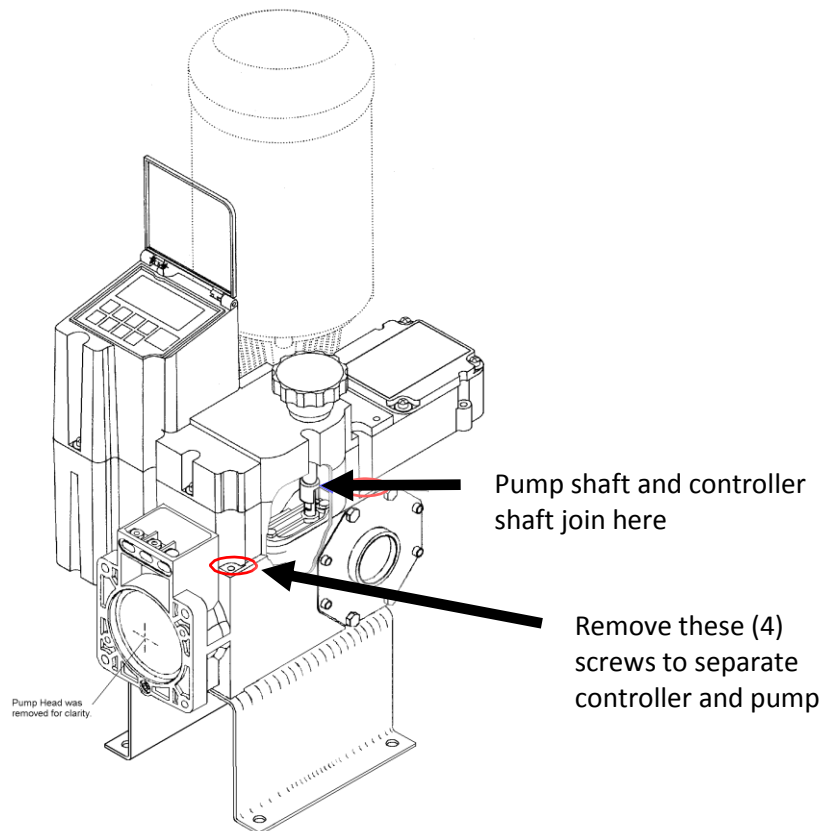

Figure 26 – Controller/Pump interface

11.2.1.3 Gear Train Problem

The internal motor and gear train used for stroke length adjustment may be damaged or worn. Some potential problems include:

1. Jammed or damaged motor
2. Broken or fractured gears
3. Gears with broken or missing teeth

11.2.1.4 Encoder Setscrew Problem

A number of encoder issues have been related to the setscrew that secures the encoder gear to the encoder shaft coming loose. Carefully check this gear by hand to ensure it is securely attached to the encoder shaft. Take care to avoid applying excessive force to the encoder shaft as this can damage it.

11.2.1.5 Electrical Problem

Electrical problems can affect both the circuit boards within the controller, and the encoder itself. The circuits within the controller cannot be tested without specialized fixtures and test equipment.

If no mechanical cause for an encoder error is located the next most likely cause is a malfunction of the encoder itself.

11.2.1.6 Pump Interface

The Pulsafeeder DLC controller connects mechanically to the PULSAR pump using a two-section shaft. The lower section is mounted within the pump, and drives the stroke adjustment mechanism, regulating the stroke length and therefore the flow output of the pump. The upper section is mounted within the controller. This allows the controller to regulate the stroke length of the pump.

11.2.1.7 Pump Stroke Length Mechanism Troubleshooting

The PULSAR metering pump utilizes a screw and slider cam system to regulate the stroke length of the pump. The screw shaft is rotated by the electronic controller. The rotation drives the wedge-shaped slider cam up or down on the shaft. As the cam moves up or down, it actuates a follower pin, which limits the rearward travel of the piston:

- a) Slider cam moves up, follower pin is moved forward for shorter strokes and lower flow rates
- b) Slider cam moves down, follower pin is moved back for longer strokes and higher flow rates

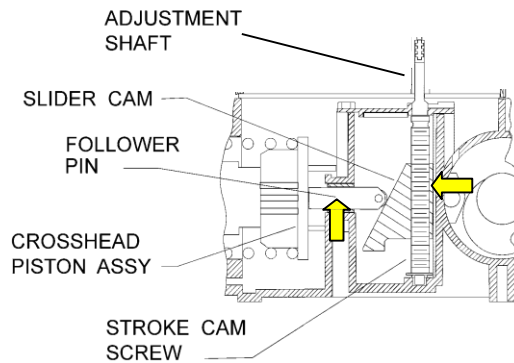

Figure 27 – Pulsar pump stroke adjustment mechanism

11.2.1.8 Possible Mechanical Malfunction Causes

1. Damage to the threads on the screw shaft, which do not allow the cam to travel smoothly
2. A bent or warped screw shaft
3. Damage to the threads on the cam
4. Damage to the face of the cam, which does not allow the follower pin to slide smoothly
5. Damage or rotation of the follower pin, which does not allow it to extend or retract smoothly.

11.2.2 Encoder/Gear Train Access

FOLLOW ALL APPROPRIATE SAFETY PROCEDURE WHEN OPENING ANY ELECTRICAL ENCLOSURE TO PROTECT PERSONEL AND PROCESSES.

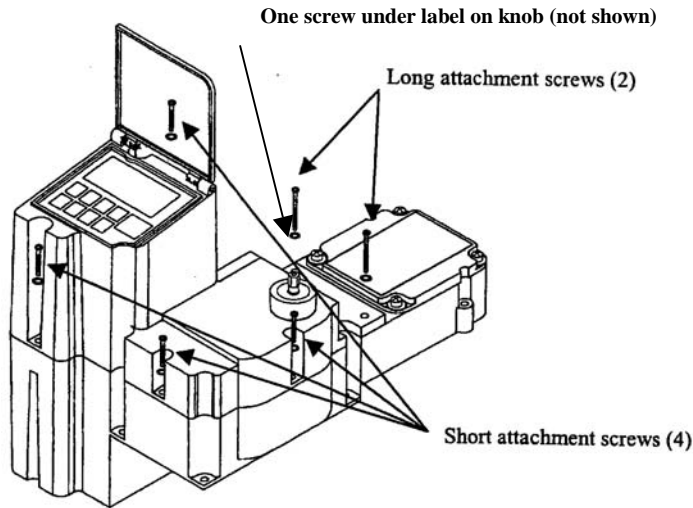

Note: For certain motor frame sizes, the DLC may have to be lifted slightly from the pump to allow access to all screws.

Figure 28 – Upper cover assembly removal



PROCEDURE:

1. Remove 6 retaining screws and the washers as shown in Figure 28.
2. Lift the top cover straight up.



FOR DLC CONTROLLERS THE KEYPAD AND DISPLAY MODULE IS ATTACHED TO THE UPPER COVER. USE CARE WHEN REMOVING THIS COVER, AS THERE IS A RIBBON CABLE THAT CONNECTS FROM THE INTERNAL CIRCUIT BOARDS TO THE UPPER COVER ASSEMBLY. RAISE THE COVER SLOWLY, UNTIL THIS WIRING CAN BE IDENTIFIED AND SECURED. THE WIRING MAY BE CAREFULLY UNPLUGGED FROM THE CIRCUIT BOARD SO THAT THE UPPER COVER ASSEMBLY CAN BE SET ASIDE FOR SERVICE.

11.2.3 Encoder Replacement

Encoders for the DLC controller come complete with the ribbon cable and plug attached. The current Pulsafeeder part number for this assembly is NP530100-000. Encoders are kept as a stock item at the factory.

To replace the encoder:

1. Disconnect power to the controller and follow all applicable procedures to ensure personal and process safety.

2. Remove the top cover from the controller as described previously in this document.
 - 2.1 Inspect the gear train for broken, worn or missing teeth. See Figure 29. If these conditions exist, contact the factory for replacement gear train.
3. Unplug the encoder cable from the circuit board.
4. Loosen the setscrew and remove the drive gear from the encoder shaft.
5. Remove the nut and lock washer (if present), and remove the encoder from the mounting plate.



CAUTION: WHEN HANDLING THE NEW ENCODER, DO NOT LOAD THE SHAFT RADIALLY (TO THE SIDE), FOR EXAMPLE WHEN ADJUSTING ITS POSITION OR TIGHTENING THE SETSCREW.

6. Install the new encoder carefully, replace the lock washer (as per the original configuration) and nut onto the shaft, but do not completely tighten them at this time.
7. Re-install the gear, aligning the height of the encoder gear to match the mating gear.
8. Apply a small drop of non-permanent locking compound to the setscrew and tighten gently, following the caution mentioned.
9. Adjust the position of the encoder as per the photographs in **Figure 29**. Allow for a small amount of backlash between the gears. There should be no radial loading of the encoder shaft. Off axis loads on this shaft will cause premature encoder failure.
10. Once position is established, tighten the encoder mounting nut to secure it to the plate.

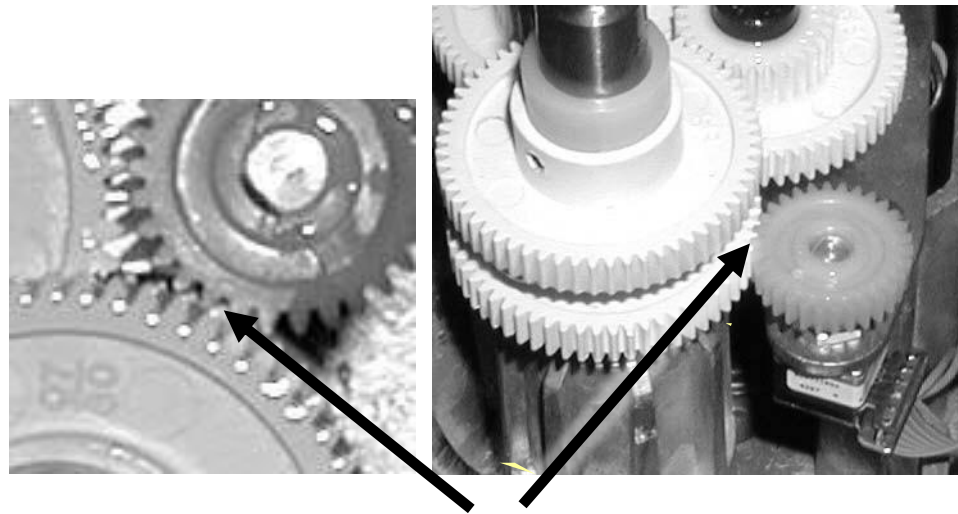

Note spacing

Figure 29 – Encoder positioning for proper gear engagement for proper gear engagement

12 Conversion (Manual to DLC)

Your PULSAR can be converted from a Manual Stroke Adjustment Mechanism to the DLC. The DLC effectively replaces the Manual Cover Assembly. Use the following procedure for conversion:

1. While running the pump motor, adjust the stroke setting to approximately 50%.
2. Disconnect the power supply going to the PULSAR drive motor. Remove AC motor and replace with DC motor. Refer to **Section 5: Installation, Pulsar Pump Motor** for motor specifications.
3. Remove the six Phillips Head screws that hold the Manual Cover Assembly to the Eccentric Box (refer to **Figure 30**).

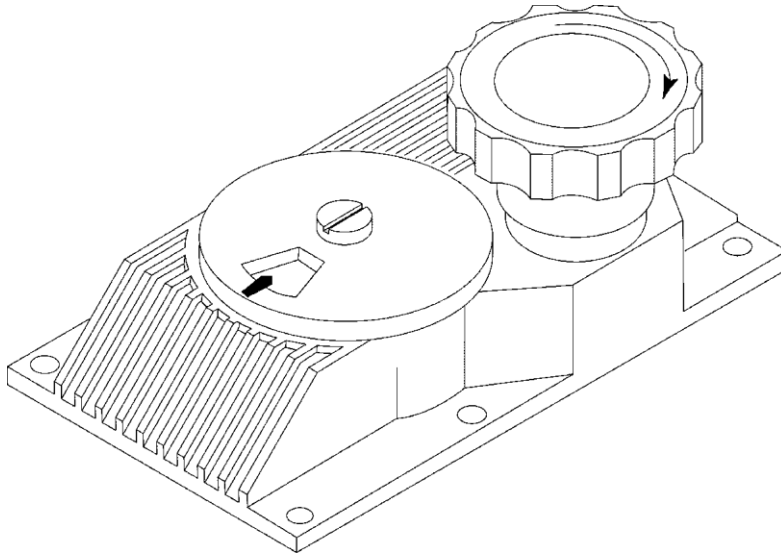

Figure 30 – Manual Cover Assembly

4. Remove the Manual Cover vertically from the Eccentric Box.
5. Visually inspect the Cam Pocket cover.
If the Cam Pocket cover is constructed out of plastic, refer to and perform the procedure defined in Bulletin No. **PMP-DLC-FCM-98** Cam Pocket Cover Replacement.
If the Cam Pocket cover is constructed out of metal continue to step 6.
6. Note the position of the adjustment shaft 'flats'. They mate with a slot in the DLC output shaft. Familiarize yourself with these mating components prior to installation (refer to **Figure 31**).

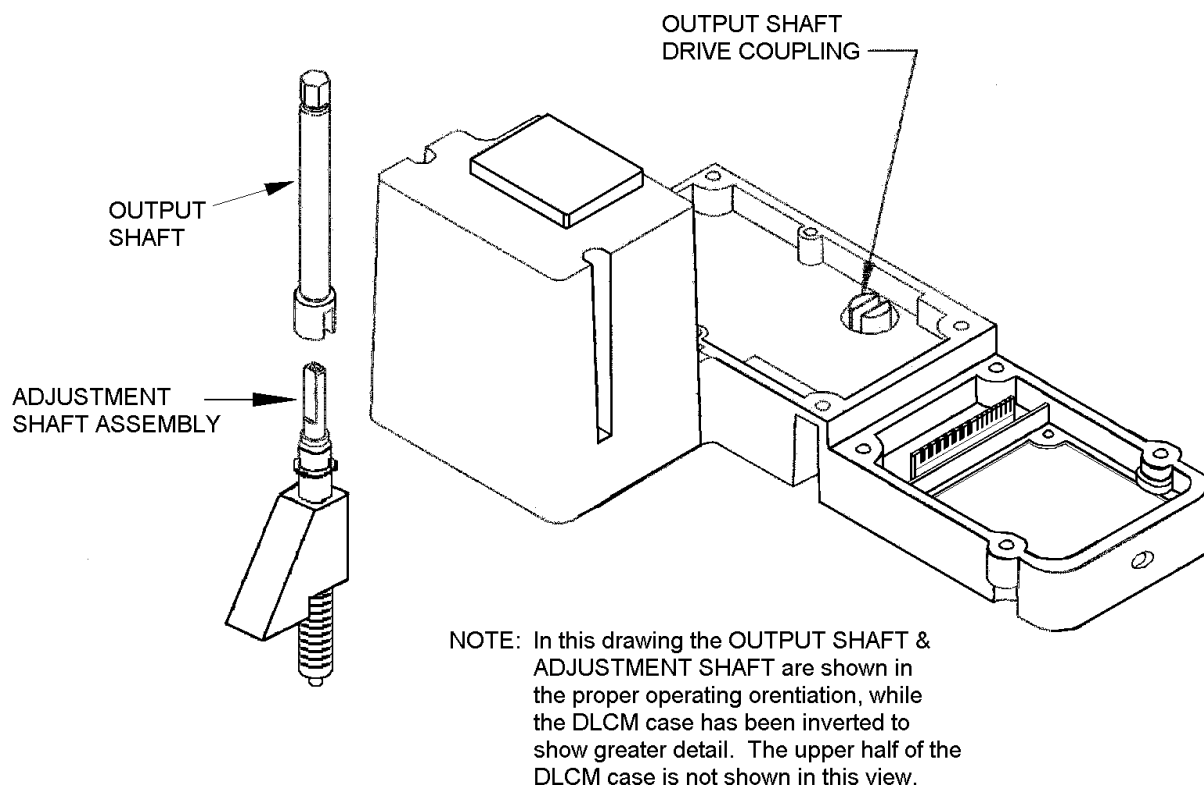

Figure 31 – DLC/Eccentric mating components

7. Locate the face on the bottom of the DLC that mates with the face of the lip of the eccentric box. The DLC is oriented such that the control pad and display sit to the left of the pump's reagent head (as viewed standing in front of the reagent head looking at the motor). The conduit connections and access panel (with Serial Tag) reside at the rear of the pump near the gear box.
8. Orient the DLC properly at a comfortable height above the pump and align the slot in the DLC coupling with the 'flats' on the adjustment shaft by turning the black hand knob on the DLC. Do not turn the adjustment shaft!
9. Lower the DLC onto the eccentric box. It may be necessary to tip the DLC slightly towards the motor to clear the motor adapter. With the DLC approximately 25mm (1 inch) above the eccentric box, make a fine adjustment to align the slot in the DLC coupling with the adjustment shaft 'flats'. Once aligned, lower the DLC to mate with the eccentric box. Do not force the cover! When the coupling is properly aligned, the DLC will seat properly under its own weight.
10. Install the 4 DLC mounting screws and washers provided.
11. Remove the 4 wiring access panel screws.
12. Follow the instructions in **Section 5: Installation, Electrical Wiring** of this manual for electrical connections of pump DC motor and tachometer.
13. Perform the steps detailed in **Section 6: Startup Instructions**.
14. Review **Section 7: General Operation** for detailed information on configuring your DLC and its advanced features.

13 General Repairs

In the unlikely event that your DLC needs service, it can be returned to Pulsafeeder for evaluation and repair. Contact PULSAFEEDER Customer Service at (585) 292-8000 for a return material authorization number and further instructions.

13.1 Emergency Manual Pulsar Operation

If your DLC is not functioning, you can operate your PULSAR manually without removing the DLC. Follow this procedure:

1. Remove power from the DLC.
2. Replace the DC motor with an AC motor or drive the DC motor with an external SCR drive.
3. Start the motor.



THE PULSAR MOTOR WILL START IMMEDIATELY! TAKE ALL NECESSARY SAFETY PRECAUTIONS.

4. Rotate the manual adjustment knob on the DLC clockwise to zero the pump. It will be difficult to rotate as you are back-driving the DLC stroke adjustment motor. Be careful! Do not force the knob. Try to turn it in both directions to get a feel for the back-drive torque. As you approach zero the knocking will diminish.
5. Once you have found zero, mark the knob and the DLC cover with pieces of tape to use as a position reference.
6. You can set the stroke adjustment to a specific value by calculating the number of knob turns. To do this, divide the desired setting (%) by a factor of 4 (%/rotation). For example, say your desired setting was 67%. You would divide 67 by 4 which equals 16.75. So you would turn the knob 16 and 3/4 revolutions in a counter-clockwise direction from the zero position.

13.2 DLC Removal and Replacement



THE FOLLOWING PROCEDURE ASSUMES THAT YOU HAVE RECEIVED YOUR DLC AND ARE READY TO PERFORM THE REPLACEMENT.

1. If possible, activate the PULSAR motor and adjust the stroke setting in the range of 10 to 90%. Avoid 0 and 100% stroke settings on the PULSAR when replacing a DLC. If necessary, use the Manual Adjustment knob. It should be easier to adjust the stroke manually in the (+) counter clockwise direction.



DO NOT ADJUST THE STROKE SETTING BEYOND THE 100% (25 TURNS FROM 0%) SETTING.

2. Disconnect the power to the DLC at the main. Power down all attached equipment (e.g., PLC's).
3. Remove the four screws and Teflon Gaskets that hold the wiring access cover to the DLC (refer to **Figure 32**).

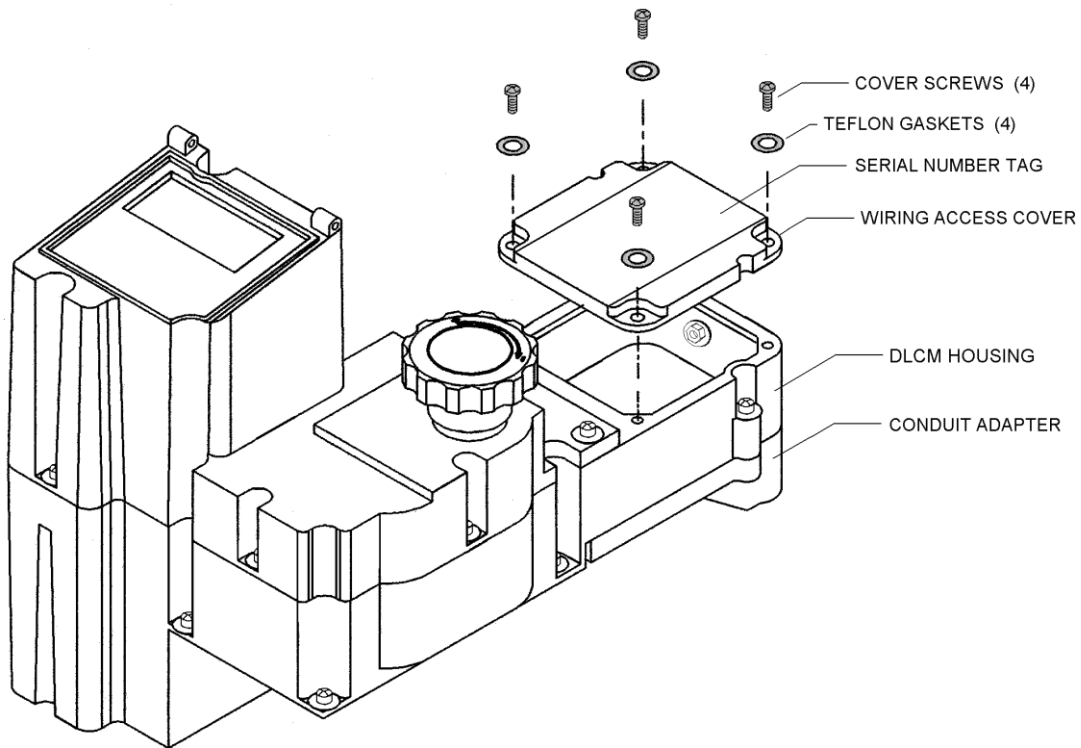

Figure 32 – Wiring Cover Access

4. Remove the Wiring Access Cover.
5. Remove the Tachometer Sensor Input Cable on the Field Wiring Board.
 - a) Disconnect the wire (typically brown) connected to Pin 1 of J10.
 - b) Disconnect the wire (typically blue) connected to Pin 2 of J10.
6. Disconnect the Tachometer Sensor Conduit Assembly nut from the Tachometer Sensor Conduit Assembly and remove the Conduit Assembly and Tachometer Sensor wire from the DLC housing.

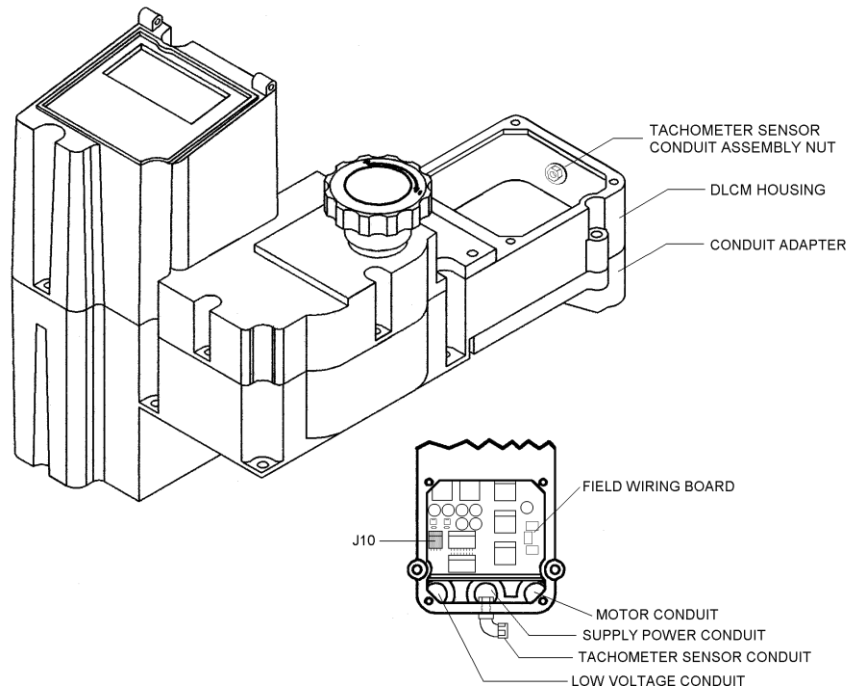

Figure 33 – Accessing the Tachometer Sensor Conduit

7. Remove the four screws and Teflon Gaskets that retain the conduit adapter(refer to **Figure 34**).

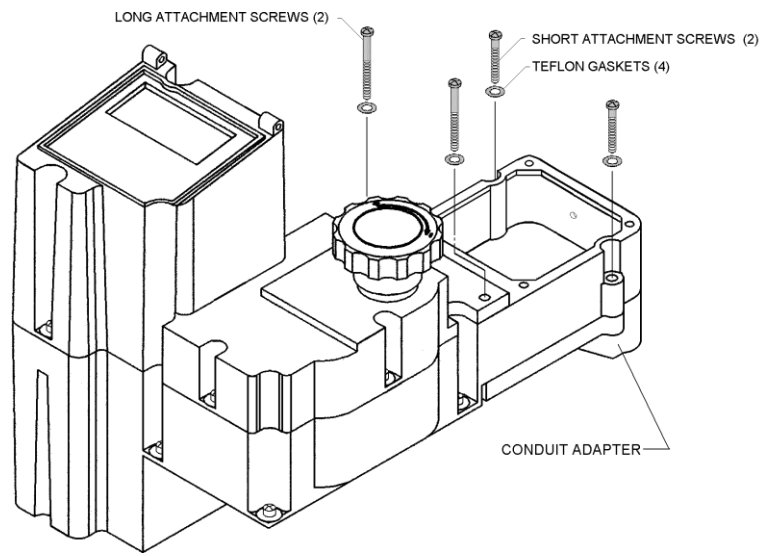

Figure 34 – Conduit Adapter Screw Removal

When removing the DLC in Step 8, the conduit adapter will stay with the wire and conduit. It plugs into the bottom of the DLC. When lifting the DLC off the Conduit Adapter, it may be necessary to have a second person hold the Adapter and associated conduit while the DLC is 'un-plugged' from it.

8. Remove the four screws that hold the DLC to the PULSAR gearbox (refer to **Figure 35**).

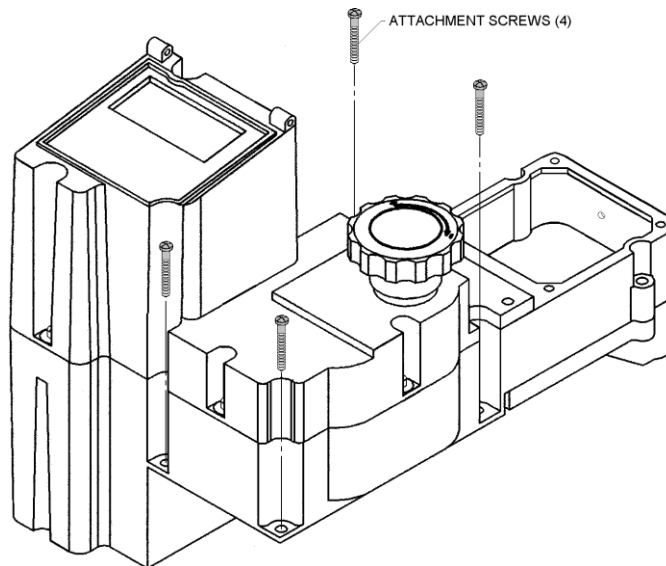

Figure 35 – DLC Removal for Replacement

9. Remove the DLC from the gear box by lifting vertically.
10. Bring the replacement DLC to the installation site.
If you are planning to re-wire the DLC during replacement, skip to step 12.
11. Remove the Conduit Adapter from the replacement DLC by performing step 7. Attach the conduit adapter to the unit being returned.

12. Note the position of the PULSAR adjustment shaft 'flats'. They mate with a slot in the DLC drive coupling of the output shaft. The output shaft is connected to the adjustment knob. Familiarize yourself with these mating components prior to installation (refer to **Figure 36**).

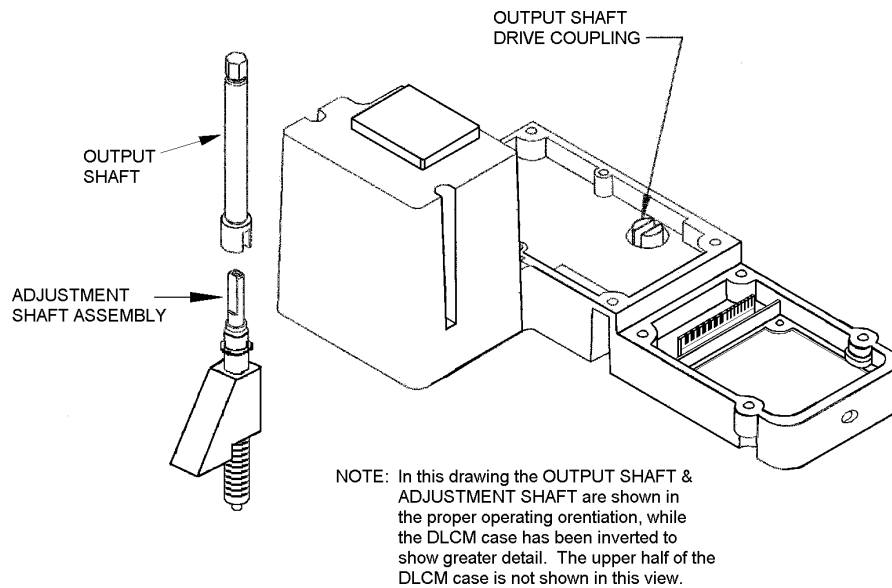

Figure 36 – DLC/Eccentric Mating Components

13. Locate the face on the bottom of the DLC that mates with the face of the lip of the gear box. The DLC is normally oriented such that the control pad and display sit to the left of the pump's reagent head (as viewed standing in front of the reagent head looking at the motor). The conduit connections and access panel (with Serial Tag) reside at the rear of the pump near the gear box (refer to **Figure 37**).

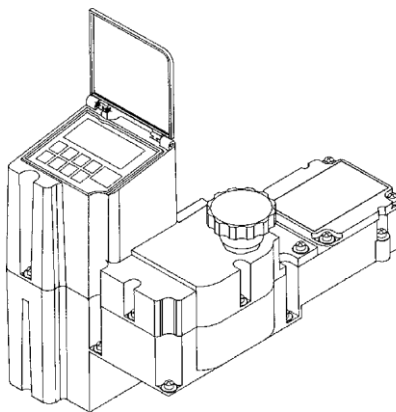

Figure 37 – Installation Orientation

Orient the DLC properly at a comfortable height above the pump and align the slot in the DLC coupling with the 'flats' on the adjustment shaft by turning the Manual Control knob on the DLC.



DO NOT TURN THE PULSAR GEAR BOX ADJUSTMENT SHAFT!

14. Lower the DLC onto the gear box.

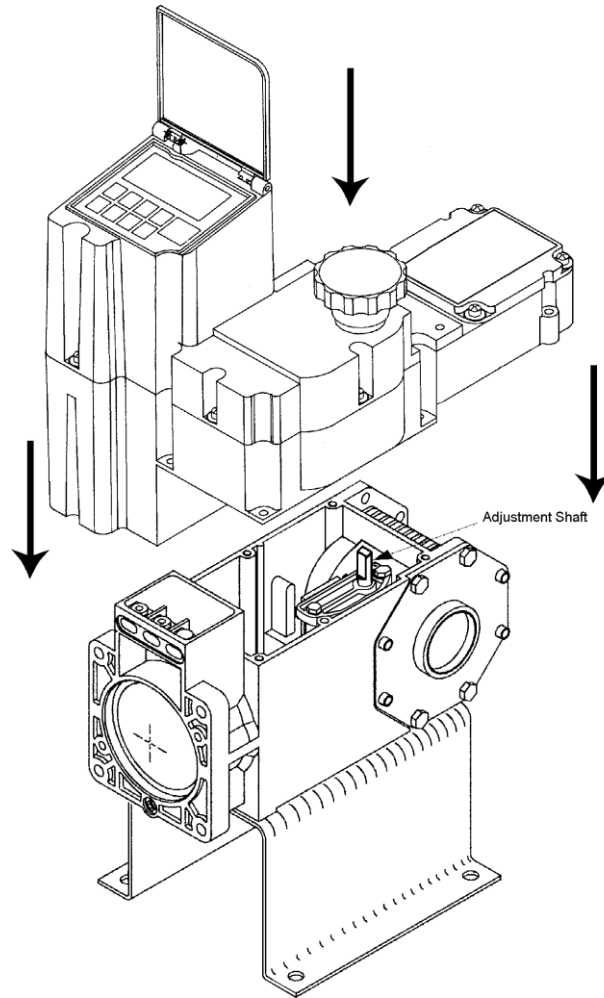

Figure 38 – Positioning the DLC

It may be necessary to tip the DLC slightly towards the motor to clear the Motor adapter.

- a) With the DLC approximately 25mm (1 inch) above the gear box, make a fine adjustment to align the slot in the DLC coupling with the adjustment shaft 'flats'.
- b) Once aligned, lower the DLC to mate with the gear box.



DO NOT FORCE THE COVER! WHEN THE COUPLING IS PROPERLY ALIGNED, THE DLC WILL SEAT ITSELF UNDER ITS OWN WEIGHT

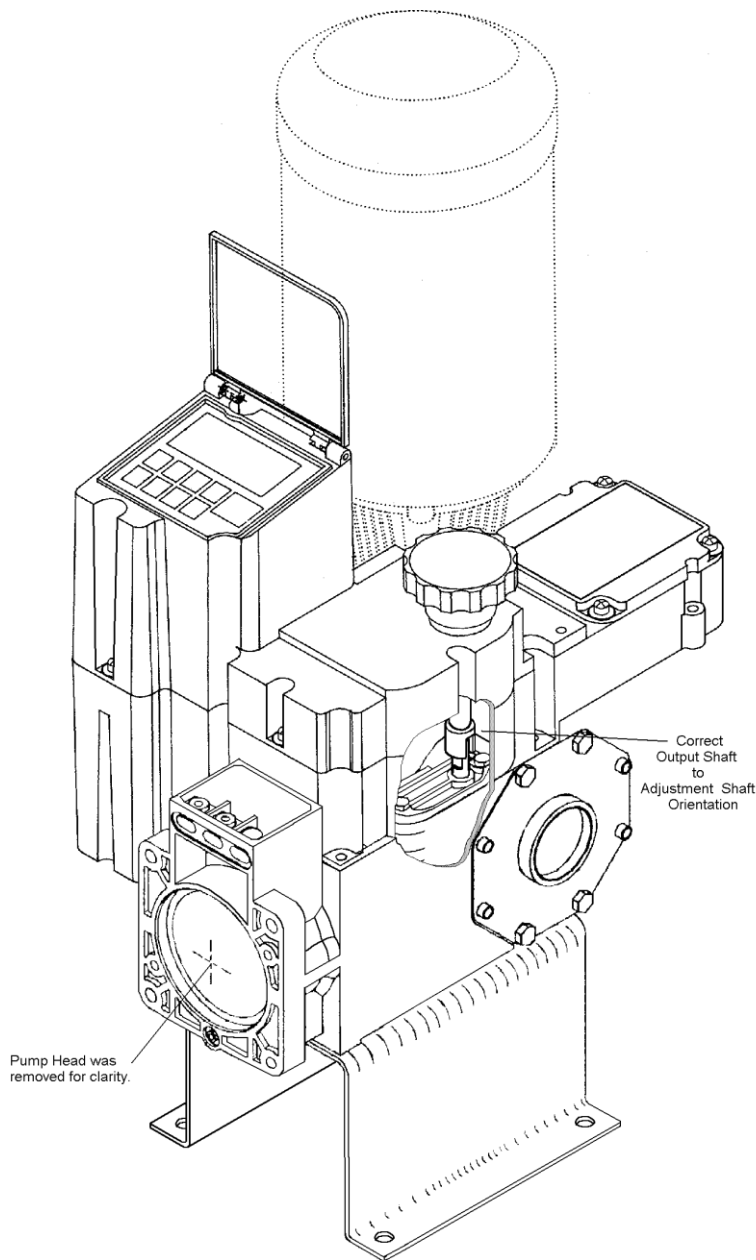

Figure 39 – Shaft Alignment

15. Align the Conduit Adapter with the mating surface on the DLC.

A card edge in the DLC housing will mate with an edge connector on the Conduit Adapter. Once properly aligned, the units will mate with moderate force (approximately 20 Newtons or 4.5 pounds of force).

a) Install the four screws and Teflon Gaskets that hold the Conduit Adapter to the DLC (refer to **Figure 34**).



FAILURE TO INSTALL THE TEFLON GASKETS WILL CAUSE YOU TO LOSE THE NEMA-4X RATING ON YOUR ENCLOSURE AND WILL VOID THE PRODUCT WARRANTY.

16. Install the 4 DLC to gearbox mounting screws (refer to **Figure 37**).

17. Remove the 4 wiring access cover screws and cover (refer to **Figure 34**).

18. Insert the Tachometer Sensor Conduit Assembly and wires (removed in step 6) in the hole provided in the back of the DLC housing.
19. Slide the Tachometer Sensor Assembly nut over the wires, and re-attach the Tachometer Sensor Conduit assembly.



YOU ARE ATTACHING A PLASTIC CONDUIT ASSEMBLY WITH A STEEL NUT. DO NOT OVER TIGHTEN OR DAMAGE WILL OCCUR TO THE CONDUIT ASSEMBLY.

20. On the Field Wiring Board, attach the wire labeled VDC (typically brown) in J10 Pin 1 (removed in step 5.a).
21. On the Field Wiring Board, attach the wire labeled TACH (typically blue) in J10 Pin 2 (removed in step 5.b).
22. Follow the instructions in **Section 5: Installation: Electrical Wiring** for electrical connections.
23. Perform the steps detailed in **Section 6: Startup**.
24. Review **Section 7-General Operation** for detailed information on configuring your DLC and its advanced features.

14 PULSAnet Specification

14.1 Introduction

The DLC PulsaNet communication system is an implementation of the industry standard MODBUS® protocol. The physical layer uses an RS-485 four-wire multi-drop scheme. Up to 32 slave units can be connected to a single master on the same set of wires. They can share those wires with PLC's and PC's that use the same method of communication.

The MODBUS protocol was created in 1978 by Modicon as a simple way for transferring data between controllers. Since its creation it has become a de-facto industry standard used by multiple control and sensor companies. Today the MODBUS® protocol is the single, most supported protocol amongst automation devices.

The MODBUS protocol is both a trademark and a fully owned product of Schneider Automation. The specification is freely distributed on the Schneider Automation home page on the World Wide Web.

With the few noted exceptions in this document, PulsaNet complies with the Schneider MODBUS protocol specification. If you are interested in developing a MODBUS application to interface with PulsaNet, please obtain the MODBUS specification from the Schneider Automation web site.

14.2 Operational Overview

The DLC has several different methods of operation when it comes to Serial Communications and MODBUS Mode.

1. A PC or PLC MASTER can Monitor Information in the DLC while it is in any mode of operation.
2. A PC or PLC MASTER can also WRITE certain information when the DLC is in MODBUS MODE.
3. A DLC MASTER can control up to 32 DLC SLAVES in a similar way that Analog signals can be used to daisy chain units together. Additional features that are available are:
 - a) The DLC SLAVE can follow the on/off motor state of the master and,
 - b) The DLC SLAVE can follow the STROKE of a DLC/M MASTER.
4. A DLC MULTIPLEX MASTER can control MULTIPLEX slaves permitting better integration of the 'motor-less' DLC's.

14.3 MODBUS Messaging

The MODBUS protocol was written for use with PLC's. Programmable Logic Controllers (PLC's) typically have relay outputs, digital inputs, analog inputs, analog outputs and general system settings (e.g., setpoints, alarm points, etc.). To access this data the PULSANET protocol uses the following basic message structure (ASCII shown):

Start	Address	Function	Data	Check	End
1 Char	2 Char	2 Char	N Char	2 Char	2 Char

Start identifies the start of a message, Address contains the slave's address, Function identifies the function to perform, Data contains the data required by the Function, Check is the LRC or CRC checksum of the message and End identifies the end of the message.

The FUNCTION CODE is the defining element in the message. It serves two purposes, 1) it defines an operation, and 2) it identifies an optional block of data as the operand. When the FUNCTION CODE operates on a block of data the ADDRESS of that data is transmitted in the DATA portion of the message. For example to read the Digital Level Input from the DLC we would use FUNCTION CODE 0x02 and ADDRESS 0x000A. To read the analog input #1 we would use FUNCTION CODE 0x04 and ADDRESS 0x0000.

These FUNCTION CODEs and associated data are organized into categories as follows:

MODBUS Category	Function Code(s)	Description	PulsaNet Application
COIL	0x01 (Read)	A relay output with either a 1 (ON) or 0 (OFF) status.	Digital output, Alarm Relay Status.
INPUT BITS	0x02 (Read)	A dry contact or open collector input with either a 1 (ON) or 0 (OFF) status.	Keyboard KEYS, LEAK, LEVEL and THERMOSTAT switch inputs.
INPUT REGISTER	0x04 (Read)	A16-bit Analog input.	4-20mA, Internal Temperatures.
HOLDING REGISTER	0x03 (Read) 0x06 (Write) 0x10 (Write Multiple)	A 16-bit multipurpose register value.	Display contents, keyboard, counters and various status and process variables.

Each PULSANET Category constitutes a block of data with ADDRESSES of 0x0000 to 0xFFFF.

The PULSANET protocol also supports FUNCTION CODEs that do not apply to data. For example, FUNCTION CODE 0x11, REPORT SLAVE ID, returns identifying information about the SLAVE (e.g., gives Run Status, Prom Version and Serial Number).

14.4 PULSAnet DDE Server Messaging

Up to this point, this discussion is related specifically to MODBUS messaging. It would typically concern someone developing an application that would communicate directly with the DLC. Most users will access data through a Data Server like the PulsaNet DDE Server. To use such a program you specify a data REFERENCE value. The server interprets the REFERENCE value to determine what FUNCTION CODE and ADDRESS should be used. In the following Data Category tables, you will find the FUNCTION CODE, ADDRESS and DDE REFERENCE relationships.

14.5 Coils

Coils are discrete, single bit outputs like the ALARM OUTPUT and DIGITAL OUTPUT.

Notes:

1. Read only.
2. The coil information is packed as 8 coils per byte.
3. Coils are accessible through Function Code 0x01.
4. The requested value is returned in the least most significant bit.

Function	Address	DDE Ref.	Purpose	Data Format
Read (0x01)	0x0000	000001	Alarm Output	Bit(0x01 = On)
Read (0x01)	0x0001	000002	Digital Output	Bit(0x01 = On)

14.6 Input Bits (1X References)

Input Bits are discrete, single bit inputs such as the keyboard KEYS, LEAK DETECTION, LEVEL INPUT and THERMOSTAT inputs.

Notes:

1. Read only.
2. The input information is packed as 8 input bits per message byte.
3. Input Bits are accessible through Function Code 0x02.
4. The requested value is returned in the least significant bit.

Function	Address	DDE Ref.	Purpose	Data Format
READ (0x02)	0x0000	100001	Key Pad Input: START/STOP	Bit(0x01=On)
READ (0x02)	0x0001	100002	Key Pad Input: BATCH	Bit(0x01=On)
READ (0x02)	0x0002	100003	Key Pad Input: UP	Bit(0x01=On)
READ (0x02)	0x0003	100004	Key Pad Input: MENU	Bit(0x01=On)
READ (0x02)	0x0004	100005	Key Pad Input: CALIBRATE	Bit(0x01=On)
READ (0x02)	0x0005	100006	Key Pad Input: DOWN	Bit(0x01=On)
READ (0x02)	0x0006	100007	Key Pad Input: UNITS	Bit(0x01=On)
READ (0x02)	0x0007	100008	Key Pad Input: MODE	Bit(0x01=On)
READ (0x02)	0x0008	100009	Key Pad Input: ENTER	Bit(0x01=On)
READ (0x02)	0x0009	100010	Digital Input: LEAK DETECT (J4-3, J4-4)	Bit(0x01=On)
READ (0x02)	0x000A	100011	Digital Input: LEVEL INPUT (J4-5, J4-6)	Bit(0x01=On)
READ (0x02)	0x000B	100012	Digital Input: MOTOR THERMOSTAT (J10-3, J10-4)	Bit(0x01=On)
READ (0x02)	0x000C	100013	Encoder: Channel B	Bit(0x01=On)
READ (0x02)	0x000D	100014	Encoder: Channel A	Bit(0x01=On)
READ (0x02)	0x000E	100015	Digital Input: Tachometer (J10-1, J10-2)	Bit(0x01=On)

14.7 Input Registers

These 16-bit input registers contain Analog (4-20mA) and Thermistor input readings.

Notes:

1. The input information is returned as 16-bit integers.
2. Input Registers are accessible through Function Code 0x04.

Function	Address	DDE Ref.	Purpose	Data Format
Read (0x04)	0x0000	300001	Raw Analog Input #1 (4-20mA): STROKE (J4-1, J4-2)	WORD (0x0 – 0xFFFF) [NOTE#1]
Read (0x04)	0x0001	300002	Raw Analog Input #2 (4-20mA): SPEED (J4-7, J4-8)	WORD (0x0 – 0xFFFF) [NOTE#1]
Read (0x04)	0x0002	300003	Raw Analog Input: MOTHER BOARD TEMPERATURE	WORD (0x0 – 0xFFFF) [NOTE#2]
Read (0x04)	0x0003	300004	Raw Analog Input: DRIVE BOARD TEMPERATURE	WORD (0x0 – 0xFFFF) [NOTE#2]

Notes:

1. This is the Raw analog value returned by the 10-bit Analog to Digital Converter. Use the following formula to yield approximate 4-20mA values:
 - a) $\text{Analog(mA)} = \text{Raw Value} * 0.025$
2. This is the raw analog value returned by the 10-bit Analog to Digital Converter. Use the following formula to yield approximate temperature:
 - a) $\text{Temperature (C)} = (\text{Raw Value} * 0.116538952) - 8.480204328$
 - b) $\text{Temperature (F)} = (\text{Raw Value} * 0.209770114) + 16.73563219$

14.8 Holding Registers

These 16-bit holding registers contain display, keyboard, counters and various status and process variables. Holding Registers are accessible through several Function Codes:

Function Code = 0x03 Read Holding Registers.

- a) Function Code = 0x06 Preset Single Holding Register.
- b) Function Code = 0x10 Preset Multiple Holding Registers.

Notes:

1. The input information is returned as 16-bit integers.
2. Reading a write-only HOLDING REGISTER will return the value that was written previously.
3. Writing to a read-only HOLDING REGISTER will NOT write and will NOT return an error.

Function	Address	DDE Ref.	Purpose	Data Format
Read (0x03)	0x0000	400001	Screen Character: Row 1, Column 1	Word (0x0 – 0xFFFF) [Note #1]
Read (0x03)	0x0001	400002	Screen Character: Row 1, Column 2	Word (0x0 – 0xFFFF) [Note #1]
Read (0x03)	0x0002	400003	Screen Character: Row 1, Column 3	Word (0x0 – 0xFFFF) [Note #1]
Read (0x03)	0x0003	400004	Screen Character: Row 1, Column 4	Word (0x0 – 0xFFFF) [Note #1]
Read (0x03)	0x0004	400005	Screen Character: Row 1, Column 5	Word (0x0 – 0xFFFF) [Note #1]
Read (0x03)	0x0005	400006	Screen Character: Row 1, Column 6	Word (0x0 – 0xFFFF) [Note #1]
Read (0x03)	0x0006	400007	Screen Character: Row 1, Column 7	Word (0x0 – 0xFFFF) [Note #1]
Read (0x03)	0x0007	400008	Screen Character: Row 1, Column 8	Word (0x0 – 0xFFFF) [Note #1]

Function	Address	DDE Ref.	Purpose	Data Format
Read (0x03)	0x0008	400009	Screen Character: Row 1, Column 9	Word (0x0 – 0xFFFF) [Note #1]
Read (0x03)	0x0009	400010	Screen Character: Row 1, Column 10	Word (0x0 – 0xFFFF) [Note #1]
Read (0x03)	0x000A	400011	Screen Character: Row 1, Column 11	Word (0x0 – 0xFFFF) [Note #1]
Read (0x03)	0x000B	400012	Screen Character: Row 1, Column 12	Word (0x0 – 0xFFFF) [Note #1]
Read (0x03)	0x000C	400013	Screen Character: Row 1, Column 13	Word (0x0 – 0xFFFF) [Note #1]
Read (0x03)	0x000D	400014	Screen Character: Row 1, Column 14	Word (0x0 – 0xFFFF) [Note #1]
Read (0x03)	0x000E	400015	Screen Character: Row 1, Column 15	Word (0x0 – 0xFFFF) [Note #1]
Read (0x03)	0x000F	400016	Screen Character: Row 1, Column 16	Word (0x0 – 0xFFFF) [Note #1]
Read (0x03)	0x0010	400017	Screen Character: Row 2, Column 1	Word (0x0 – 0xFFFF) [Note #1]
Read (0x03)	0x0011	400018	Screen Character: Row 2, Column 2	Word (0x0 – 0xFFFF) [Note #1]
Read (0x03)	0x0012	400019	Screen Character: Row 2, Column 3	Word (0x0 – 0xFFFF) [Note #1]
Read (0x03)	0x0013	400020	Screen Character: Row 2, Column 4	Word (0x0 – 0xFFFF) [Note #1]
Read (0x03)	0x0014	400021	Screen Character: Row 2, Column 5	Word (0x0 – 0xFFFF) [Note #1]
Read (0x03)	0x0015	400022	Screen Character: Row 2, Column 6	Word (0x0 – 0xFFFF) [Note #1]
Read (0x03)	0x0016	400023	Screen Character: Row 2, Column 7	Word (0x0 – 0xFFFF) [Note #1]
Read (0x03)	0x0017	400024	Screen Character: Row 2, Column 8	Word (0x0 – 0xFFFF) [Note #1]
Read (0x03)	0x0018	400025	Screen Character: Row 2, Column 9	Word (0x0 – 0xFFFF) [Note #1]
Read (0x03)	0x0019	400026	Screen Character: Row 2, Column 10	Word (0x0 – 0xFFFF) [Note #1]
Read (0x03)	0x001A	400027	Screen Character: Row 2, Column 11	Word (0x0 – 0xFFFF) [Note #1]
Read (0x03)	0x001B	400028	Screen Character: Row 2, Column 12	Word (0x0 – 0xFFFF) [Note #1]
Read (0x03)	0x001C	400029	Screen Character: Row 2, Column 13	Word (0x0 – 0xFFFF) [Note #1]
Read (0x03)	0x001D	400030	Screen Character: Row 2, Column 14	Word (0x0 – 0xFFFF) [Note #1]
Read (0x03)	0x001E	400031	Screen Character: Row 2, Column 15	Word (0x0 – 0xFFFF) [Note #1]
Read (0x03)	0x001F	400032	Screen Character: Row 2, Column 16	Word (0x0 – 0xFFFF) [Note #1]
Read (0x03)	0x0020	400033	Flash Character: Row 2, Column 1	Word (0x0 – 0xFFFF) [Note #1]
Read (0x03)	0x0021	400034	Flash Character: Row 1, Column 2	Word (0x0 – 0xFFFF) [Note #1]
Read (0x03)	0x0022	400035	Flash Character: Row 1, Column 3	Word (0x0 – 0xFFFF) [Note #1]
Read (0x03)	0x0023	400036	Flash Character: Row 1, Column 4	Word (0x0 – 0xFFFF) [Note #1]
Read (0x03)	0x0024	400037	Flash Character: Row 1, Column 5	Word (0x0 – 0xFFFF) [Note #1]
Read (0x03)	0x0025	400038	Flash Character: Row 2, Column 6	Word (0x0 – 0xFFFF) [Note #1]
Read (0x03)	0x0026	400039	Flash Character: Row 2, Column 7	Word (0x0 – 0xFFFF) [Note #1]
Read (0x03)	0x0027	400040	Flash Character: Row 1, Column 8	Word (0x0 – 0xFFFF) [Note #1]
Read (0x03)	0x0028	400041	Flash Character: Row 1, Column 9	Word (0x0 – 0xFFFF) [Note #1]
Read (0x03)	0x0029	400042	Flash Character: Row 1, Column 10	Word (0x0 – 0xFFFF) [Note #1]
Read (0x03)	0x002A	400043	Flash Character: Row 1, Column 11	Word (0x0 – 0xFFFF) [Note #1]
Read (0x03)	0x002B	400044	Flash Character: Row 1, Column 12	Word (0x0 – 0xFFFF) [Note #1]
Read (0x03)	0x002C	400045	Flash Character: Row 1, Column 13	Word (0x0 – 0xFFFF) [Note #1]
Read (0x03)	0x002D	400046	Flash Character: Row 1, Column 14	Word (0x0 – 0xFFFF) [Note #1]
Read (0x03)	0x002E	400047	Flash Character: Row 1, Column 15	Word (0x0 – 0xFFFF) [Note #1]
Read (0x03)	0x002F	400048	Flash Character: Row 1, Column 16	Word (0x0 – 0xFFFF) [Note #1]
Read (0x03)	0x0030	400049	Flash Character: Row 2, Column 1	Word (0x0 – 0xFFFF) [Note #1]
Read (0x03)	0x0031	400050	Flash Character: Row 2, Column 2	Word (0x0 – 0xFFFF) [Note #1]
Read (0x03)	0x0032	400051	Flash Character: Row 2, Column 3	Word (0x0 – 0xFFFF) [Note #1]
Read (0x03)	0x0033	400052	Flash Character: Row 2, Column 4	Word (0x0 – 0xFFFF) [Note #1]
Read (0x03)	0x0034	400053	Flash Character: Row 2, Column 5	Word (0x0 – 0xFFFF) [Note #1]
Read (0x03)	0x0035	400054	Flash Character: Row 2, Column 6	Word (0x0 – 0xFFFF) [Note #1]
Read (0x03)	0x0036	400055	Flash Character: Row 2, Column 7	Word (0x0 – 0xFFFF) [Note #1]
Read (0x03)	0x0037	400056	Flash Character: Row 2, Column 8	Word (0x0 – 0xFFFF) [Note #1]
Read (0x03)	0x0038	400057	Flash Character: Row 2, Column 9	Word (0x0 – 0xFFFF) [Note #1]
Read (0x03)	0x0039	400058	Flash Character: Row 2, Column 10	Word (0x0 – 0xFFFF) [Note #1]

Function	Address	DDE	Purpose	Data Format
Read (0x03)	0x003A	400059	Flash Character: Row 2, Column 11	Word (0x0 – 0xFFFF) [Note #1]
Read (0x03)	0x003B	400060	Flash Character: Row 2, Column 12	Word (0x0 – 0xFFFF) [Note #1]
Read (0x03)	0x003C	400061	Flash Character: Row 2, Column 13	Word (0x0 – 0xFFFF) [Note #1]
Read (0x03)	0x003D	400062	Flash Character: Row 2, Column 14	Word (0x0 – 0xFFFF) [Note #1]
Read (0x03)	0x003E	400063	Flash Character: Row 2, Column 15	Word (0x0 – 0xFFFF) [Note #1]
Read (0x03)	0x003F	400064	Flash Character: Row 2, Column 16	Word (0x0 – 0xFFFF) [Note #1]
Read (0x03)	0x0040	400065	Cursor: Flag & Position	Word (0x0 – 0xFFFF) [Note #2]
Write (0x06) Write Mult.	0x0041	400066	Key-press	Word (0x0 – 0xFFFF) [Note #3]
Read (0x03) Write (0x06) Write Mult. (0x10)	0x0042	400067	Pump Motor Status	Word (0x0 – 0xFFFF) [Note #4]
Read (0x03) Write (0x06) Write Mult. (0x10)	0x0043	400068	Desired Percent Stroke (hundredths %)	Word (0x0 – 0xFFFF) [Note #5]
Read (0x03) Write (0x06) Write Mult. (0x10)	0x0044	400069	Desired Percent Speed (hundredths %)	Word (0x0 – 0xFFFF) [Note #6]
Read (0x03) Write (0x06) Write Mult. (0x10)	0x0045	400070	Stroke Counter High 16 Bits	Word (0x0 – 0xFFFF) [Note #7]
Read (0x03) Write (0x06) Write Mult. (0x10)	0x0046	400071	Stroke Counter Low 16 Bits	Word (0x0 – 0xFFFF) [Note #7]
Read (0x03)	0x0047	400072	Under/Over Voltage Error Flag	Word (0x0 – 0xFFFF) [Note #8]
Read (0x03)	0x0048	400073	Actual Stroke Position (hundredths %)	Word (0x0 – 0xFFFF) [Note #9]
Read (0x03) Write (0x06) Write Mult. (0x10)	0x0049	400074	Actual Average Motor Speed (hundredths %)	Word (0x0 – 0xFFFF) [Note #9]
Read (0x03)	0x004A	400075	Security PIN #	(0000-9999) [Note #10]
Read (0x03)	0x004B	400076	Security Type	(0,1,2) [Note #11]
Read (0x03)	0x004C	400077	Current Mode	(0,1,2,3) [Note #12]
Read (0x03)	0x004D	400078	Find Zero Calibration	(0,1) [Note #13]
Read (0x03)	0x004E	400079	Year of Century	(00-99)
Read (0x03)	0x004F	400080	Month of Year	(1-12)
Read (0x03)	0x0050	400081	Day of Month	(1-31)
Read (0x03)	0x0051	400082	Day of Week	(1-7, 1 = Sunday)
Read (0x03)	0x0052	400083	Hour of Day	(0-23)
Read (0x03)	0x0053	400084	Minute of Hour	(0-59)
Read (0x03)	0x0054	400085	Second of Minute	(0-59)
Read (0x03)	0x0055	400086	Motor Type	(0=AC, 1=DC, 2=None)

Notes:

1. There is one character per 16-bit value, which resides in the least significant byte.
2. The most significant byte contains the cursor status (0 = cursor off, 1 = cursor on). The least significant byte contains the cursor position offset (0-15 for the first line and 16-31 for the second).
3. Used to invoke Key-presses. The key value must be sent in the least significant byte (the most significant byte is unused).



THIS REGISTER (0X0041 – KEY PRESS) MUST NOT BE USED FOR AUTOMATION PURPOSES. IT CAN PRESENT HAZARDOUS CONDITIONS TO THE OPERATOR. ACTIVATING CODE 0X01 (STOP_START_KEY) WILL OVERRIDE LOCAL KEYPAD CONTROL! USE REGISTER 0X0042 – PUMP MOTOR STATUS FOR AUTOMATED MOTOR CONTROL.

Note that the UP Key and Down Key are inhibited from modifying the stroke length. Use 0x0043 for that purpose. The following codes are assigned:

0 = 0x00 =	NO_KEY	10 = 0x0A =	UP_ENTER_KEY
1 = 0x01 =	STOP_START_KEY (motor	11 = 0x0B =	DOWN_KEY
2 = 0x02 =	MENU_KEY	12 = 0x0C =	DN_REPEAT_KEY
3 = 0x03 =	UNITS_KEY	13 = 0x0D =	DN_ENTER_KEY
4 = 0x04 =	BATCH_KEY	14 = 0x0E =	UP_DOWN_KEY
5 = 0x05 =	CALIBRATE_KEY	15 = 0x0F =	SECRET_1_KEY
6 = 0x06 =	MODE_KEY	16 = 0x10 =	SECRET_2_KEY
7 = 0x07 =	ENTER_KEY	17 = 0x11 =	SECRET_3_KEY
8 = 0x08 =	UP_KEY	18 = 0x12 =	TIMEOUT_KEY
9 = 0x09 =	UP_REPEAT_KEY		

- The most significant byte contains the desired condition (0 = user desires pump off, 1 = user desires pump on). The least significant byte contains the actual motor status (0 = pump motor off, 1 = pump motor on). When writing, only write to the Most Significant byte. The Least Significant byte must be set to 0x00 or an error will be returned.
- Percent-Stroke value is expressed in hundredths of percent i.e. 0x01F4 = 500 = 5.00%. The 0-10,000 value range may be modified by Ratio and Reverse Acting and further limited by end-points.
- Percent-Speed value is expressed as hundredths of percent i.e. 0x2710 = 10000 = 100.00%. The 0-10,000 value range may be modified by Ratio and Reverse Acting and further limited by end-points. This value is write-able only in a DLC. A DLC will always return 100.00%.
- Stroke Counter 16-bits (Most significant or Least significant depending on register). The combination of these addresses constitutes a 32-bit unsigned LONG value. It is useful only if the tachometer option is installed (e.g., DLC).
- The least significant bit contains the Under/Over Voltage Flag (0=False[No Error], 1=True[Error]).
- The Actual Stroke Position value is expressed in hundredths of percent i.e. 0x01F4 = 500 = 5.00%.
- The Actual Average Motor Speed value is expressed in hundredths of percent i.e. 0x01F4 = 500 = 5.00%. The Average Interval is 10 pump strokes. Writing any value will reset the Average.
- Writing while security is disabled sets a new PIN #. Writing while security is enabled compares to the old PIN #.
- Reading returns the current condition from RAM that can be either 0=Security Off, 1=Tamper Proof, 2=Calibration Settings. Writing while security is disabled, enables the chosen security type. NOTE that you should write the PIN # before enabling security here.
- This is provided because you can only write items while in MODBUS MODE. 0=MANUAL MODE, 1=ANALOG MODE, 2=MODBUS MODE, 3=BATCH MODE.
- Reading determines if we are currently performing a Find Zero Calibration. (0=no, 1=in progress) This register can be written with a '1' to force a Find Zero Calibration to occur.

SUPPORTED FUNCTION CODES and SUB-FUNCTION CODES

0x01	READ COIL STATUS (bits)	SUPPORTED
0x02	READ INPUT STATUS (bits).	SUPPORTED
0x03	READ HOLDING REGISTERS (16-bit integers)	SUPPORTED
0x04	READ INPUT REGISTERS (16-bit integers)	SUPPORTED
0x05	FORCE SINGLE COIL (bits)	NOT supported
0x06	PRESET SINGLE HOLDING REGISTER (16-bit integer)	SUPPORTED
0x07	READ EXCEPTION STATUS (8-bits only)	NOT supported
0x08	DIAGNOSTIC FUNCTIONS	PARTIALLY
	0x0000 RETURN QUERY DATA (ECHO)	SUPPORTED
	0x0001 RESTART COMMUNICATIONS PORT	SUPPORTED
	0x0002 RETURN DIAGNOSTIC REGISTER	NOT supported
	0x0003 CHANGE ASCII INPUT DELIMITER <LF>	SUPPORTED
	0x0004 SET LISTEN ONLY MODE	SUPPORTED
	0x0005 - 0x0009 reserved	NOT supported
	0x000A CLEAR CTRS AND DIAGNOSTIC REGISTER	NOT supported
	0x000B RETURN BUS MESSAGE COUNT	NOT supported
	0x000C RETURN BUS COMM. ERROR COUNT	NOT supported
	0x000D RETURN BUS EXCEPTION ERROR COUNT	NOT supported
	0x000E RETURN SLAVE MESSAGE COUNT	NOT supported
	0x000F RETURN SLAVE NO RESPONSE COUNT	NOT supported
	0x0010 RETURN SLAVE NAK COUNT	NOT supported
	0x0011 RETURN SLAVE BUSY COUNT	NOT supported
	0x0012 RETURN BUS CHAR. OVERRUN COUNT	NOT supported
	0x0013 RETURN OVERRUN ERROR COUNT	NOT supported
	0x0014 CLEAR OVERRUN COUNTER AND FLAG	NOT supported
	0x0015 GET/CLEAR MODBUS® PLUS STATISTICS	NOT supported
	0x0016 - 0xFFFF reserved	NOT supported
0x09	PROGRAM MODICON 484 CONTROLLER	NOT supported
0x0A	POLL MODICON 484 CONTROLLER	NOT supported
0x0B	FETCH COMMUNICATIONS EVENT COUNTER	NOT supported
0x0C	FETCH COMMUNICATIONS EVENT LOG	NOT supported
0x0D	PROGRAM CONTROLLER	NOT supported
0x0E	POLL CONTROLLER	NOT supported
0x0F	FORCE MULTIPLE COILS.	NOT supported
0x10	PRESET MULTIPLE HOLDING REGISTERS	SUPPORTED
0x11	REPORT SLAVE ID	SUPPORTED

----- Return Message Contains -----

0x22 = Byte Count (length of data field to follow) (34 decimal)

0x99 = Slave ID

0x## = Run Status (of the pump motor) 0x00=off, 0xFF=on

16 characters from prom_ver[] string like: " 1.24 "

16 characters from Serial Number string entered at Factory Setup

Example: "B156045-D10 "

0x12	PROGRAM 884/M84	NOT Supported
0x13	RESET COMMUNICATIONS LINK	NOT supported
0x14	READ GENERAL REFERENCE	NOT supported
0x15	WRITE GENERAL REFERENCE	NOT supported
0x16	MASK WRITE 4X REGISTERS.	NOT supported
0x17	READ/WRITE 4X REGISTERS.	NOT supported
0x18	READ FIFO QUEUE	NOT supported
0x19 to 0x7f	UNUSED	NOT assigned
Exception: 0x6f is used ONLY for the DLC to DLC MODBUS Mode.		

Notes:

1. Function codes that are NOT SUPPORTED or NOT ASSIGNED return an ILLEGAL FUNCTION CODE response.
2. Unsupported SUB-FUNCTION CODES under DIAGNOSTIC FUNCTIONS return INVALID DATA.MODBUS Mode

14.9 MODBUS Mode

14.9.1 Introduction

The serial communications supplied with the DLC/M is similar in operation to that with the 4-20mA signal. The [MODE] key controls the current operating mode: MANUAL, ANALOG (4-20mA) or MODBUS. Serial communications can occur with the DLC/M regardless of the mode setting. Never the less, only when the DLC/M is in the MODBUS MODE can a value be written – changing the operation of the device. In any other mode, values can only be read. Note that even in MODBUS MODE, the arrow keys cannot be used to adjust the flow or stroke length.

14.9.2 General Discussion

A PC or PLC MASTER controls a DLC SLAVE by writing to the Holding Registers for Percent Stroke, Percent Speed and Motor Status values. When the MASTER READS from the Stroke and Speed, it retrieves the User Desired Position and User Desired Speed. When the MASTER WRITES to the Stroke and Speed, it changes the Digital-Stroke and Digital-Speed values. This allows the application of the RATIO and REVERSE ACTING factors and checking of the end points limits. The written values must be in the range of 0.00% – 100.00% (0-10000). In addition, if this is **NOT** a **DLC**, writing anything at all to the Motor Speed will return an error. The FLOW RATE cannot be set directly by the MASTER, it is calculated from the Stroke and Speed settings.



WARNING: FOR SAFETY, IF AN OPERATOR WANTS TO DISABLE THE MODBUS REMOTE CONTROL OF THE DLC, THEN THEY MUST SWITCH THE DLC OUT OF MODBUS MODE. TURNING OFF THE MOTOR WILL NOT PROTECT THEM AGAINST THE PUMP BEING TURNED BACK ON BY THE PC/PLC. WHENEVER PERFORMING MAINTENANCE, THE POWER SHOULD BE REMOVED COMPLETELY FROM THE DLC.

To prevent operators from modifying the operation of the DLC (e.g., changing the MODE from MODBUS to MANUAL), Tamper Proof Security should be invoked. When doing this, carefully select options in the {MODBUS SIG. FAIL} menu. If the DLC/DLC is configured to restore to MANUAL MODE, and a MODBUS signal failure is detected, the PC/PLC will no longer be in control of the DLC. If Security is enabled, then operators will not be able to control the DLC/DLC either (except for the motor key, which is never protected by security).

15 Spare Parts

User replaceable parts for the DLC.

Table 4: Miscellaneous Replacement Parts

Pulsafeeder P/N	Description	Qty
NP250012-000	Clear Lexan Keypad / Display Cover	1
NP991209-003	Cover Pins	2
NP260003-GPC	Manual Adjustment Knob	1
NP550003-DLC	Manual Adjustment Knob Decal	1
NP992207-STL	Connector Board Assembly Screw (short)	2
NP992208-STL	Connector Board Assembly Screw (long)	2
NP992205-STL	Wiring Access Cover Screw	4
NP460016-TFE	Teflon Screw Gasket	8



Installation, Operation & Maintenance Instruction Manual

PULSAR[®] DLC NEMA TYPE 4x DIGITAL STROKE CONTROLLER

Bulletin No.: IOM-CTL-DLC-2005



Pulsafeeder, Inc.
A unit of IDEX Corporation
2883 Brighton Henrietta Town Line Road
Rochester NY 14623
+1 (585) 292-8000
www.pulsa.com
pulsa@idexcorp.com

